

COVER ASSEMBLES ONTO 38" X 44" OD  
BOLT-DOWN CONCAST PULL BOX

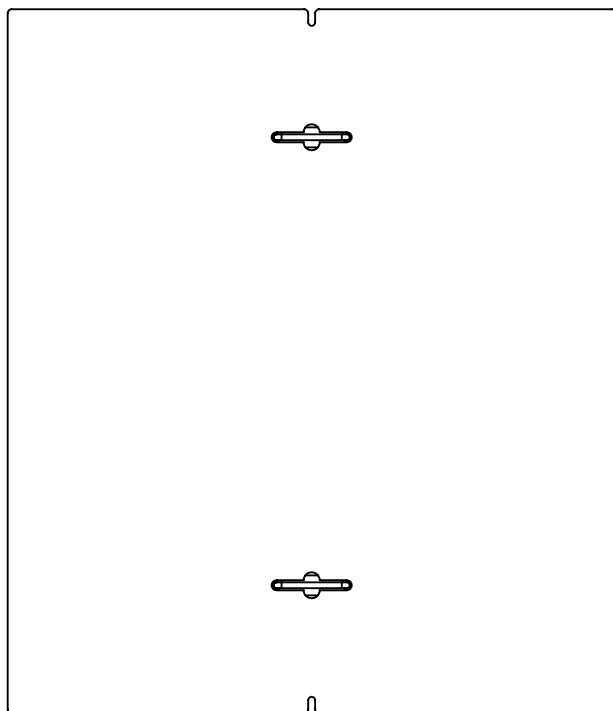

LIFTING RING (2X)  
SHOWN EXTENDED

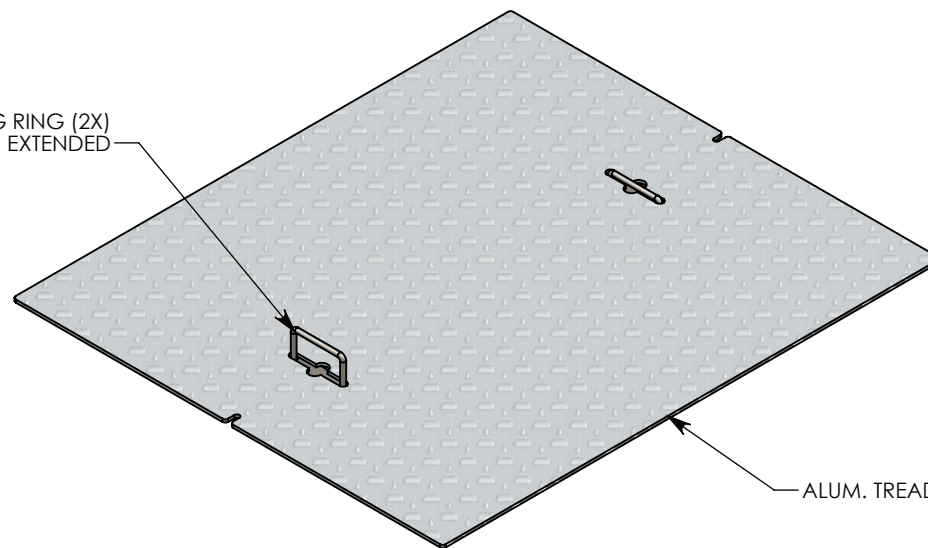

ALUM. TREAD PLATE

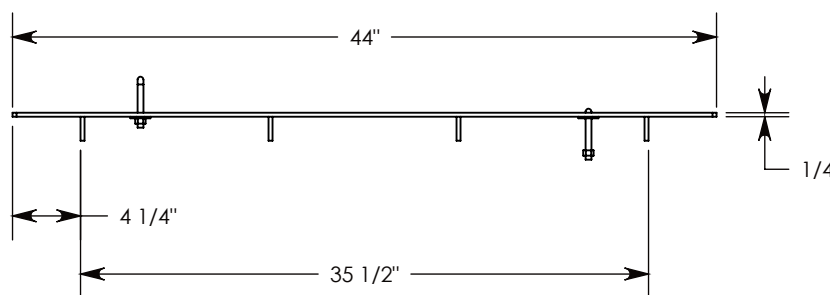
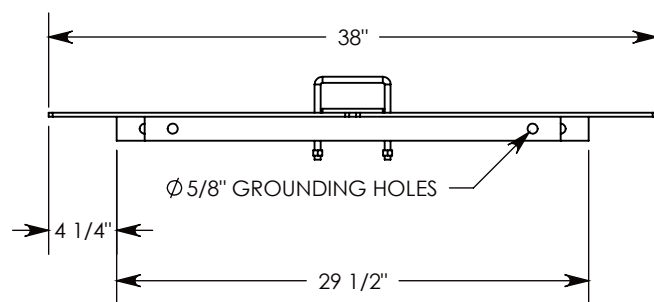

PEDESTRIAN RATED - 200 LB. PER SQ. FOOT

**DRAWN BY: ROBIN FLINT**

**DATE: 9/25/2015**

**REVISION LEVEL: A**

**WEIGHT:**

**48 LBS.**

**MATERIAL:**

**WELDED ALUMINUM**



1010 NORTH STAR DRIVE  
P.O. BOX 69  
ZUMBROTA, MN 55992-0069

**DESCRIPTION:**

**ALUM. PED. BOLT-DOWN PULL BOX COVER**

DIMENSIONS ARE IN INCHES  
TOLERANCES:  
FRACTIONAL:  $\pm 1/8"$   
ANGULAR:  $\pm 2^\circ$

CONTACT INFORMATION:  
EMAIL: INFO@CONCASTINC.COM  
PHONE: (507) 732-4095  
FAX: (507) 732-4094

SHEET 1 OF 1

**PART NUMBER:**

**38-44-ABD**