

FIBERCRETE[®]
TRENCH SYSTEM

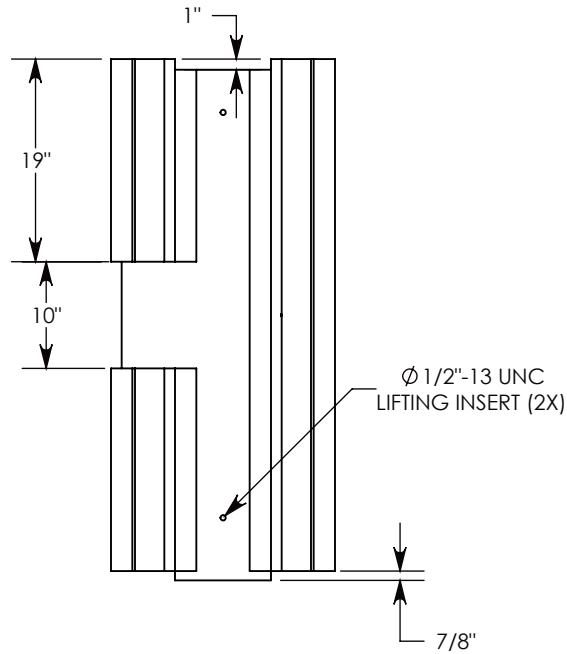

1 7/8" X 1 7/8" GALV. STEEL TOP RAIL (TYP.)

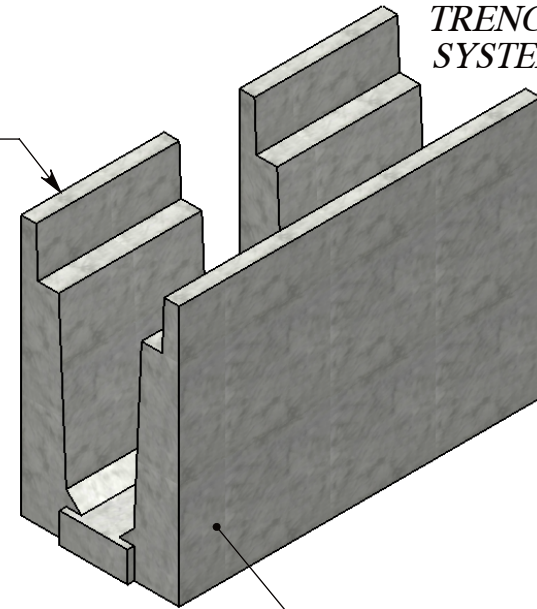

STEEL REINFORCED CONCRETE

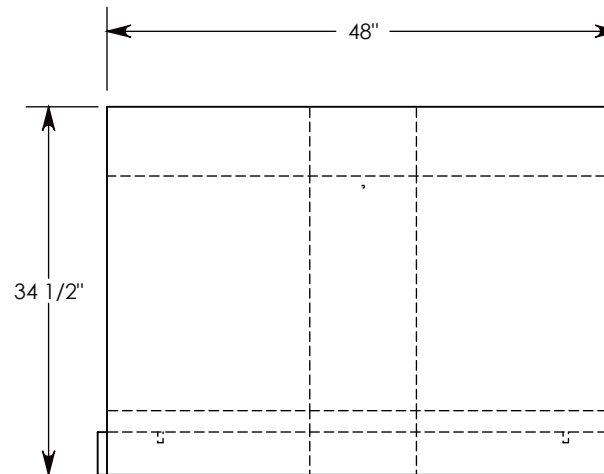
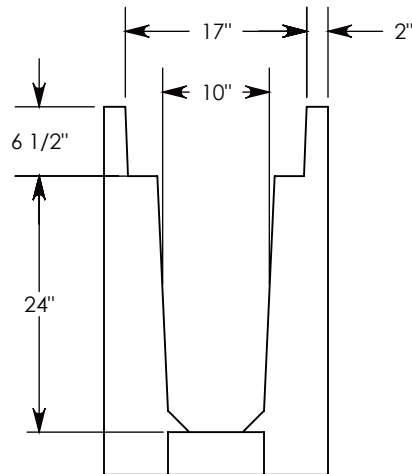

H-20 RATED - 32,000 LB. PER AXLE LOAD

DRAWN BY: ROBIN LEWIS

DATE: 7/11/2011

REVISION LEVEL: 0

WEIGHT:

1374 LBS.

MATERIAL:

CONCRETE

CONCAST
 1010 NORTH STAR DRIVE
 P.O. BOX 69
 ZUMBROTA, MN 55992-0069

DESCRIPTION:

HEAVY TRAFFIC UNIVERSAL CHANNEL

DIMENSIONS ARE IN INCHES

TOLERANCES:
 FRACTIONAL: $\pm 1/8$ "
 ANGULAR: $\pm 2^\circ$

CONTACT INFORMATION:
 EMAIL: INFO@CONCASTINC.COM
 PHONE: (507) 732-4095
 FAX: (507) 732-4094

SHEET 1 OF 1

PART NUMBER:

801224HT (0X10)