

FIBERCRETE[®]
TRENCH SYSTEM

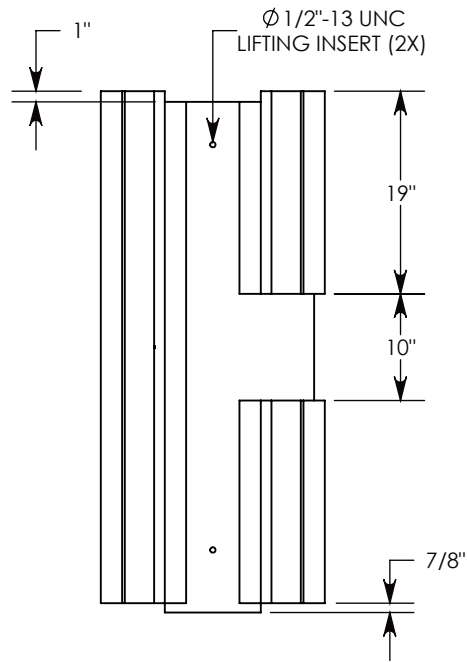

1 7/8" X 1 7/8" GALV. STEEL TOP RAIL (TYP.)

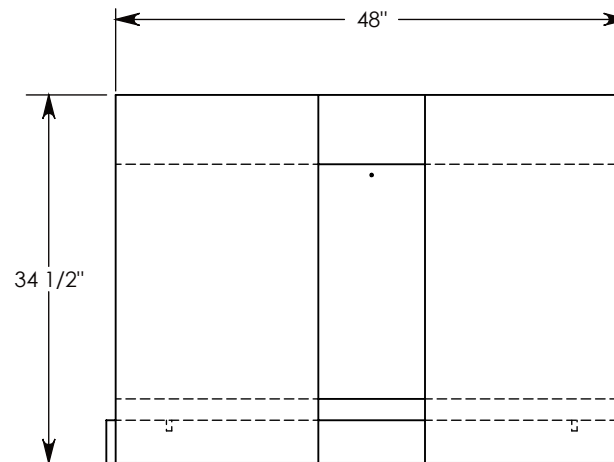
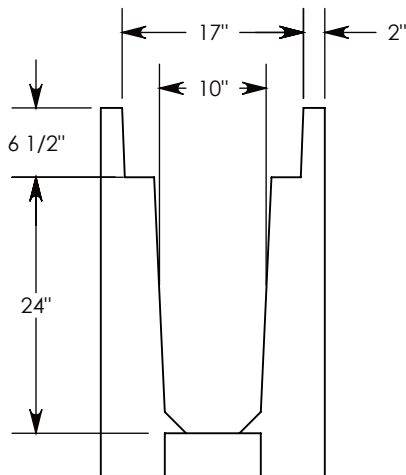
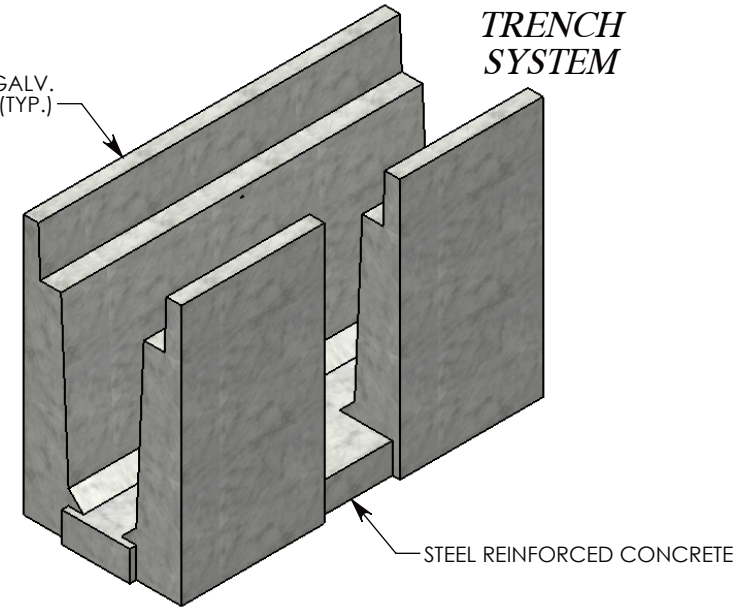

H-20 RATED - 32,000 LB. PER AXLE LOAD

DRAWN BY: ROBIN LEWIS

DATE: 7/11/2011

REVISION LEVEL: 0

WEIGHT:

1374 LBS.

MATERIAL:

CONCRETE



1010 NORTH STAR DRIVE
P.O. BOX 69
ZUMBROTA, MN 55992-0069

DESCRIPTION:

HEAVY TRAFFIC UNIVERSAL CHANNEL

DIMENSIONS ARE IN INCHES
TOLERANCES:
FRACTIONAL: ± 1/8"
ANGULAR: ± 2°

CONTACT INFORMATION:
EMAIL: INFO@CONCASTINC.COM
PHONE: (507) 732-4095
FAX: (507) 732-4094

SHEET 1 OF 1

PART NUMBER:

801224HT (10X0)