

**FIBERCRETE<sup>®</sup>**  
**TRENCH SYSTEM**

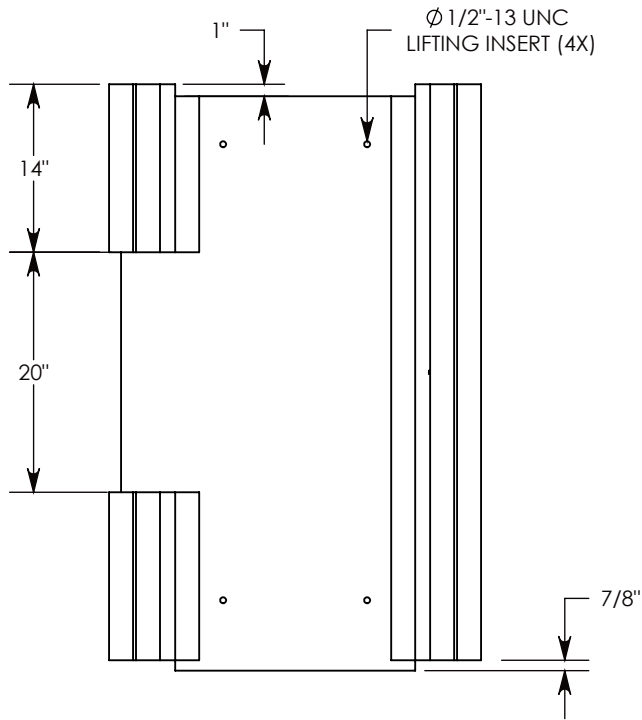

GALV. STEEL TOP RAIL (TYP.)

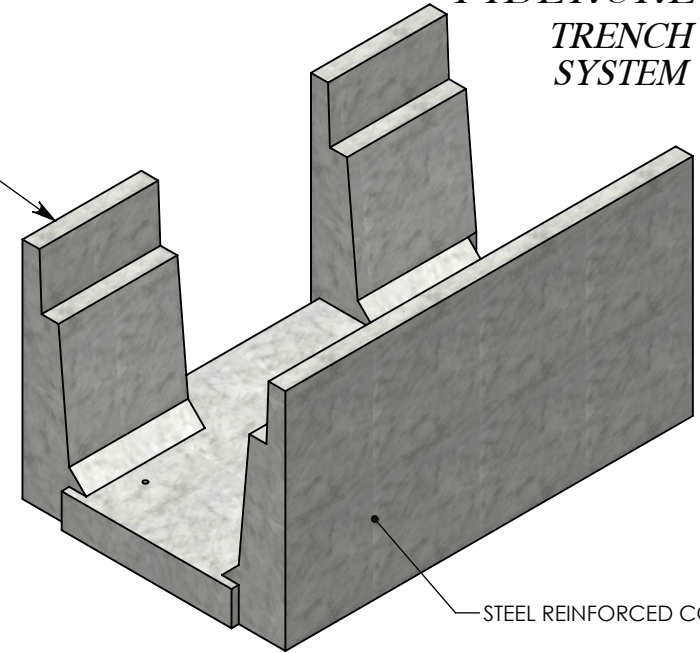

STEEL REINFORCED CONCRETE

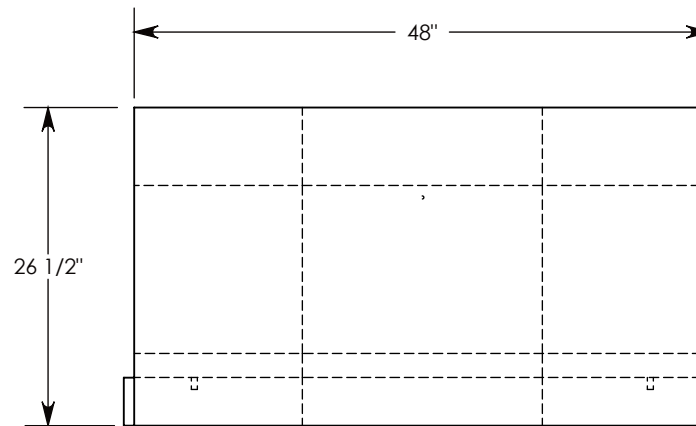
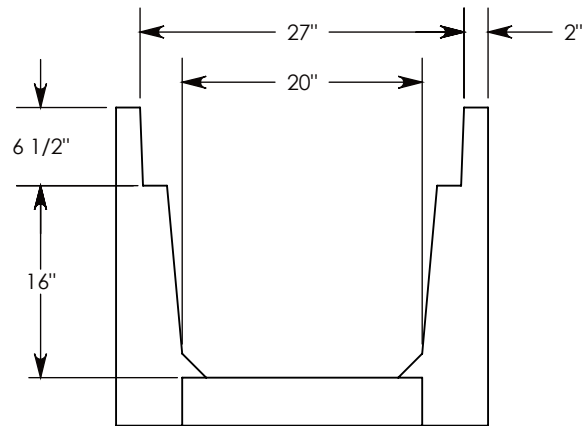

H-20 RATED - 32,000 LB. PER AXLE LOAD

**DRAWN BY: ROBIN FLINT**

**DATE: 11/19/2015**

**REVISION LEVEL: 0**

**WEIGHT:**

**1071 LBS.**

**MATERIAL:**

**CONCRETE**

**CONCAST**  
 1010 NORTH STAR DRIVE  
 P.O. BOX 69  
 ZUMBROTA, MN 55992-0069

**DESCRIPTION:**

**HEAVY TRAFFIC UNIVERSAL CHANNEL**

DIMENSIONS ARE IN INCHES  
 TOLERANCES:  
 FRACTIONAL:  $\pm 1/8\text{'}$   
 ANGULAR:  $\pm 2^\circ$

CONTACT INFORMATION:  
 EMAIL: [INFO@CONCASTINC.COM](mailto:INFO@CONCASTINC.COM)  
 PHONE: (507) 732-4095  
 FAX: (507) 732-4094

SHEET 1 OF 1

**PART NUMBER:**

**802216HT (0X20)**