

FIBERCRETE[®]
TRENCH
SYSTEM

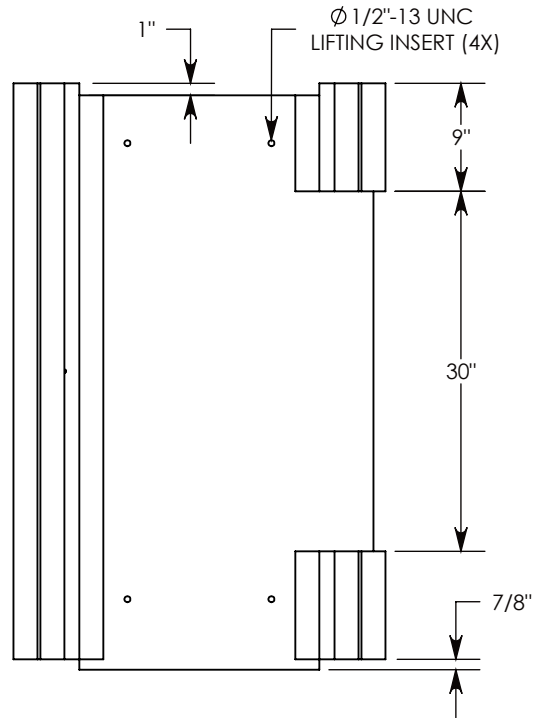

GALV. STEEL TOP RAIL (TYP.)

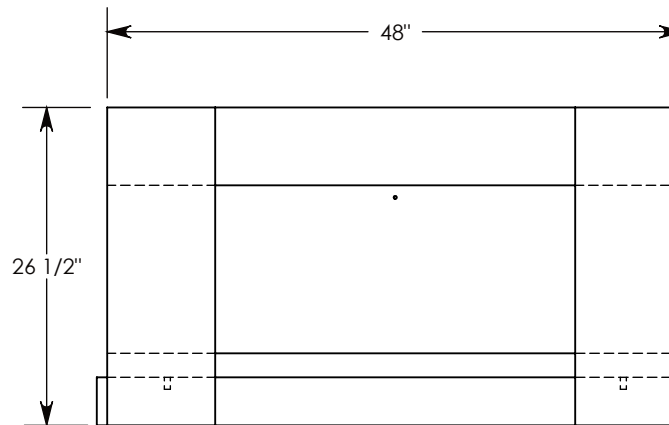
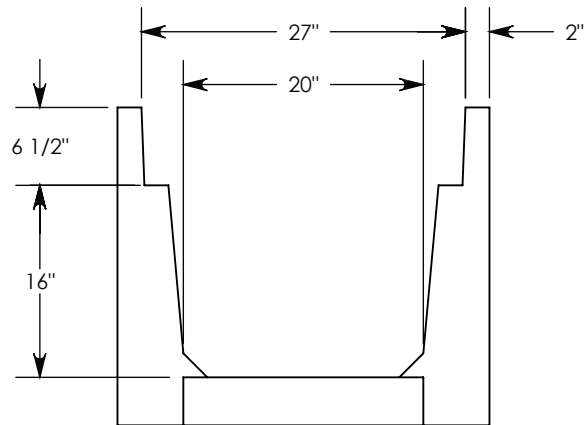
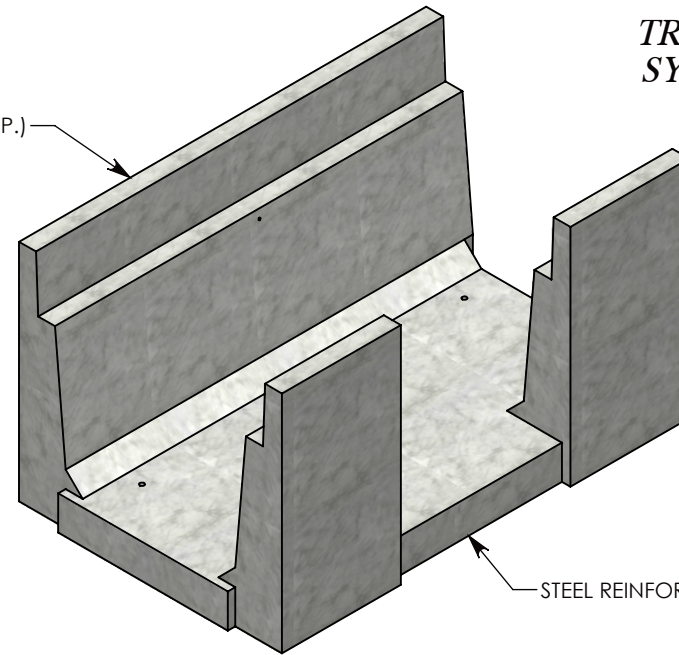

H-20 RATED - 32,000 LB. PER AXLE LOAD

DRAWN BY: ROBIN FLINT

DATE: 11/19/2015

REVISION LEVEL: 0

WEIGHT:

1071 LBS.

MATERIAL:

CONCRETE

CONCAST
 1010 NORTH STAR DRIVE
 P.O. BOX 69
 ZUMBROTA, MN 55992-0069

DESCRIPTION:

HEAVY TRAFFIC UNIVERSAL CHANNEL

DIMENSIONS ARE IN INCHES

TOLERANCES:
 FRACTIONAL: ± 1/8"
 ANGULAR: ± 2°

CONTACT INFORMATION:
 EMAIL: INFO@CONCASTINC.COM
 PHONE: (507) 732-4095
 FAX: (507) 732-4094

SHEET 1 OF 1

PART NUMBER:

802216HT (20X0)