

**FIBERCRETE<sup>®</sup>**  
**TRENCH SYSTEM**

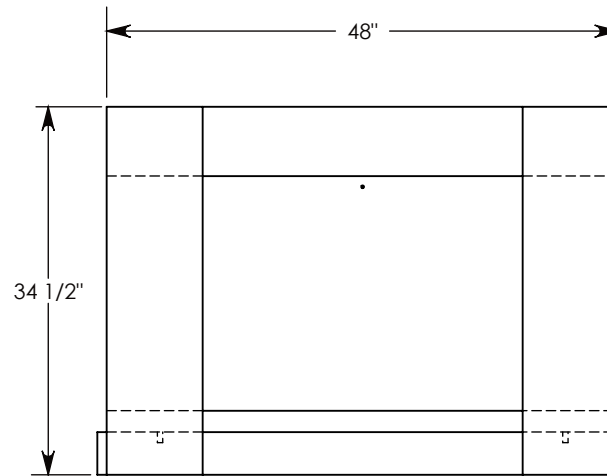
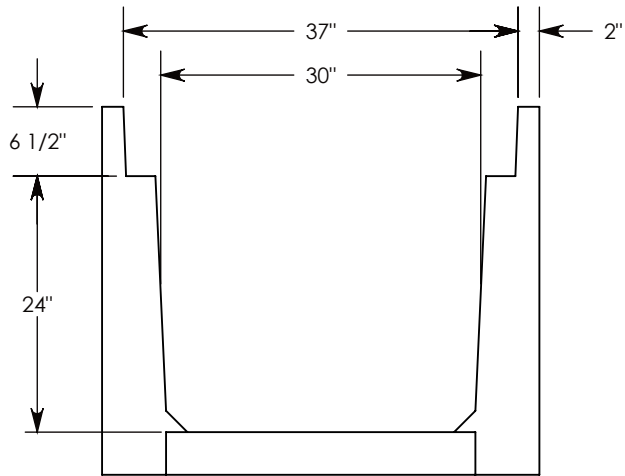
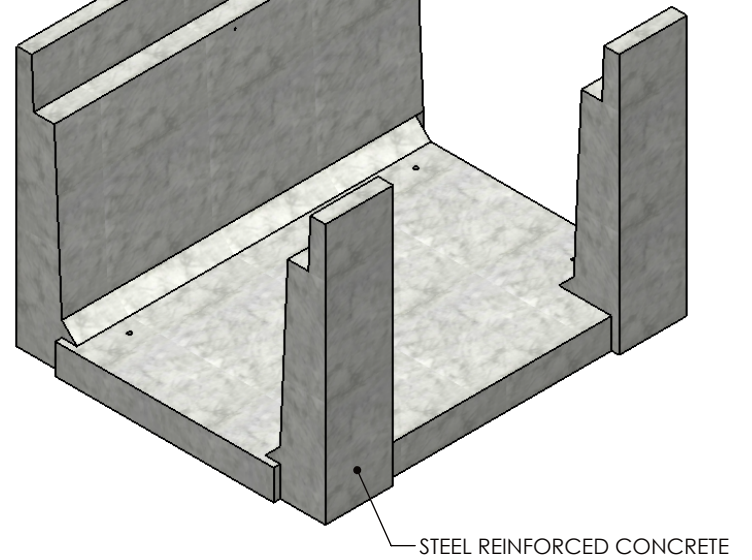

H-20 RATED - 32,000 LB. PER AXLE LOAD

**DRAWN BY: ROBIN LEWIS**

**DATE: 7/11/2011**

**REVISION LEVEL: 0**

**WEIGHT:**

**1438 LBS.**

**MATERIAL:**

**CONCRETE**

**CONCAST**  
 1010 NORTH STAR DRIVE  
 P.O. BOX 69  
 ZUMBROTA, MN 55992-0069

**DESCRIPTION:**

**HEAVY TRAFFIC UNIVERSAL CHANNEL**

DIMENSIONS ARE IN INCHES

TOLERANCES:  
 FRACTIONAL:  $\pm 1/8$ "  
 ANGULAR:  $\pm 2^\circ$

CONTACT INFORMATION:  
 EMAIL: [INFO@CONCASTINC.COM](mailto:INFO@CONCASTINC.COM)  
 PHONE: (507) 732-4095  
 FAX: (507) 732-4094

SHEET 1 OF 1

**PART NUMBER:**

**803224HT (30X0)**