

REV. A - DRB - 7/21/2023 - UPDATED TO USE COVER SUPPORT. RF-8/4/23 SECONDARY EDITS
 REV. B - SIC - 9/18/2023 - UPDATED AND CORRECTED ANNOTATIONS; UPDATED WEIGHT RATING; ADDED MISSING DIMENSIONS

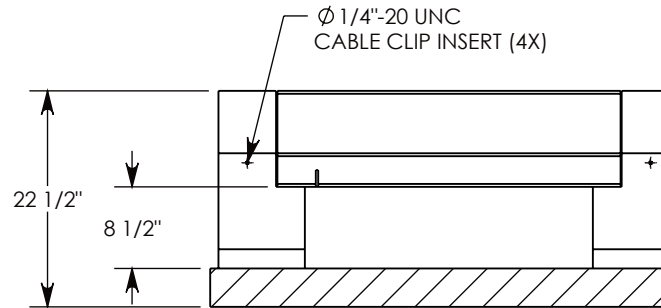
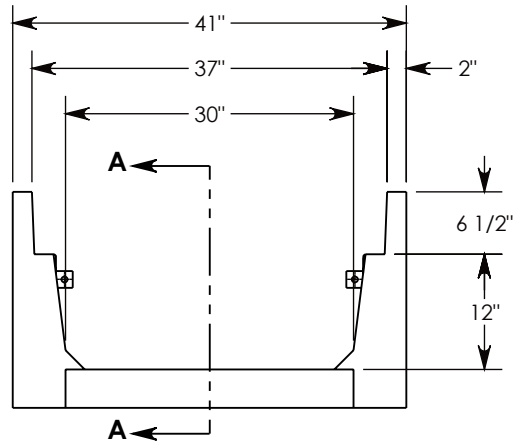
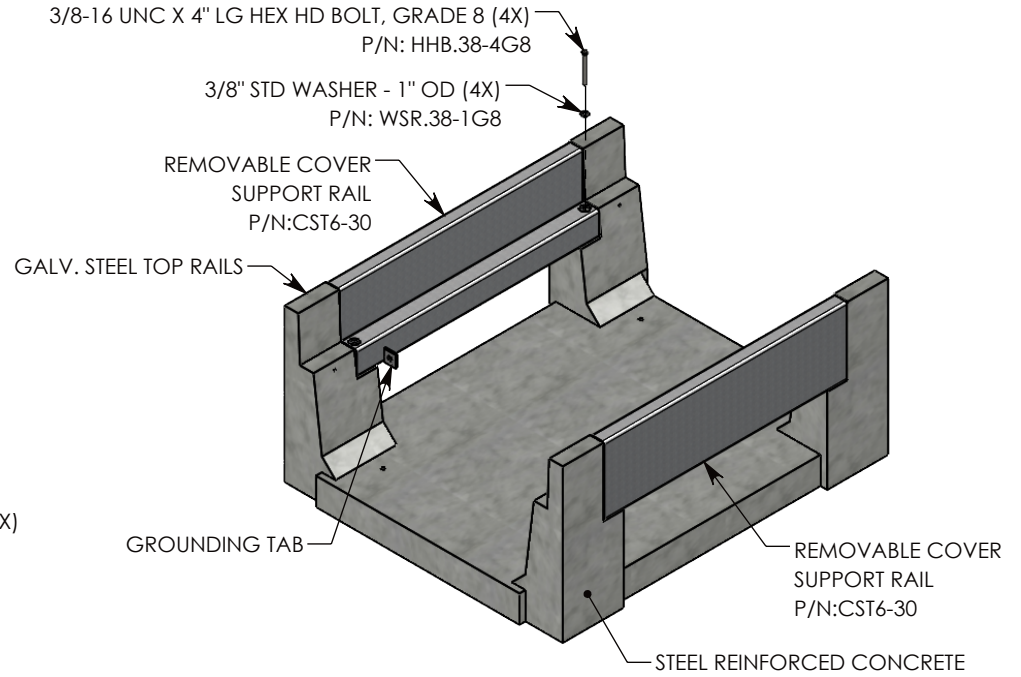
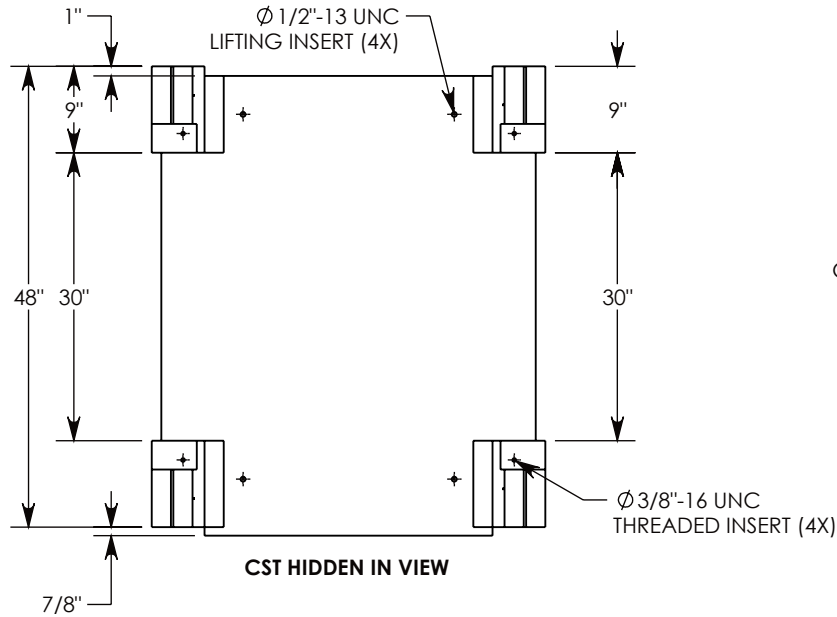

SECTION A-A

MAX AASHTO H-40 RATED - 64,000 LB. SINGLE AXLE LOAD.
 DEPENDENT ON TRENCH COVER RATING

DRAWN BY: ROBIN LEWIS	
CREATED DATE: 7/14/2008	REVISION LEVEL: B
SAVED DATE: 9/18/2023	SAVED BY: scallahan
WEIGHT: 959 LBS.	MATERIAL: NOTED

1010 NORTH STAR DRIVE
 P.O. BOX 69
 ZUMBROTA, MN 55992-0069

DESCRIPTION:		SHEET 1 OF 1
HEAVY TRAFFIC UNIVERSAL CHANNEL		
DIMENSIONS ARE IN INCHES	CONTACT INFORMATION:	
TOLERANCES:	EMAIL: INFO@CONCASTINC.COM	
FRACTIONAL: $\pm 1/8"$	PHONE: (507) 732-4095	
ANGULAR: $\pm 2^\circ$	FAX: (507) 732-4094	
PART NUMBER:		
8032HT (30X30)		