

**FIBERCRETE<sup>®</sup>**  
**TRENCH SYSTEM**

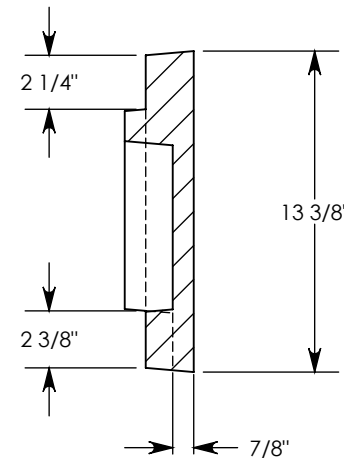
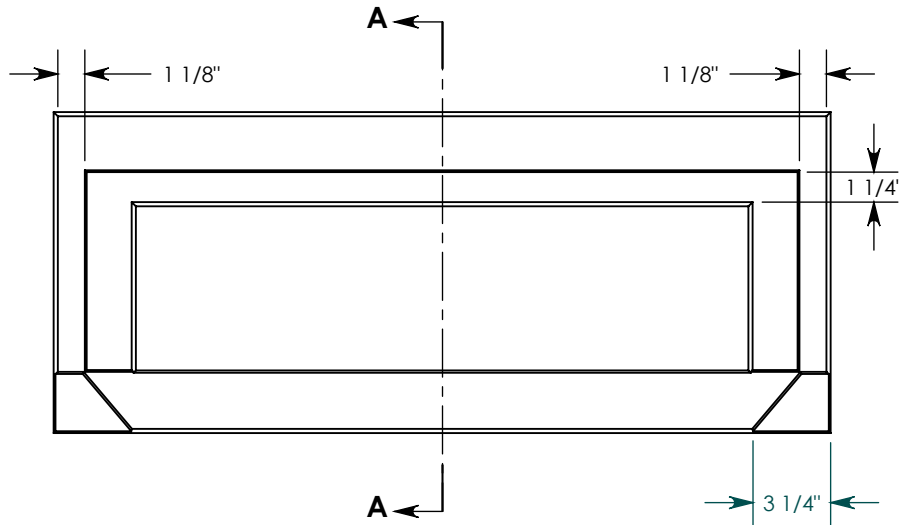
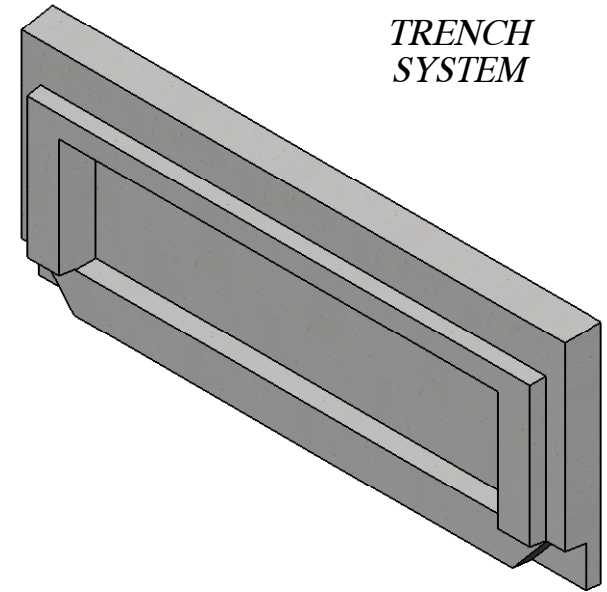
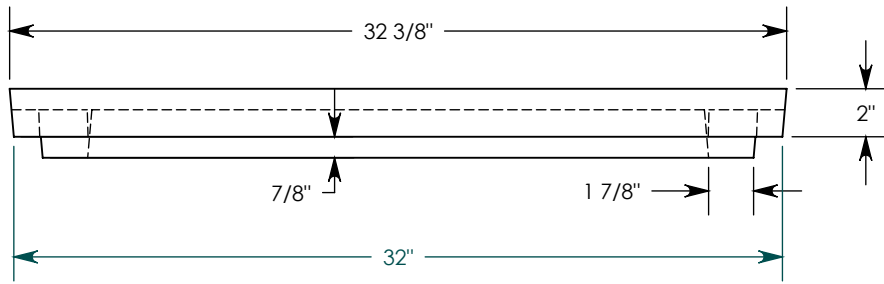

**SECTION A-A**

PEDESTRIAN RATED - 200 LB. PER SQ. FOOT

**DRAWN BY: ROBIN LEWIS**

**DATE: 9/21/2010**

**REVISION LEVEL: 0**

**WEIGHT:**

**58 LBS.**

**MATERIAL:**

**CAST FIBERCRETE**



**DESCRIPTION:**

**END PLATE**

DIMENSIONS ARE IN INCHES  
 TOLERANCES:  
 FRACTIONAL: ± 1/8"  
 ANGULAR: ± 2°

CONTACT INFORMATION:  
 EMAIL: INFO@CONCASTINC.COM  
 PHONE: (507) 732-4095  
 FAX: (507) 732-4094

SHEET 1 OF 1

**PART NUMBER:**

**8033**