

REV. A - DRB - 7/21/2023 - UPDATED TO USE COVER SUPPORT. RF-8/15/23 SECONDARY EDITS

REV. B - SIC - 9/19/2023 - UPDATED WEIGHT RATING NOTE; FLIPPED SECTION A-A; ADDED MISSING DIMENSIONS; UPDATED/CORRECTED ANNOTATIONS; Ø 1/4"-20 UNC INSERT (4X), WAS (3X)

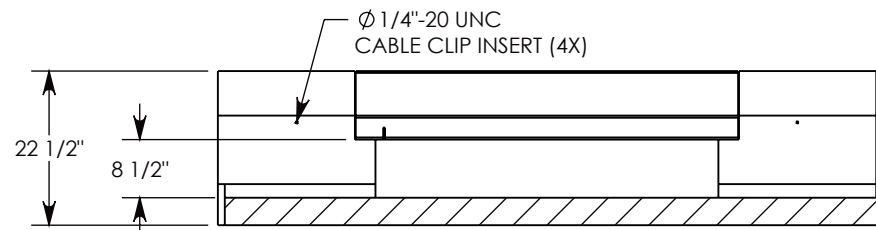
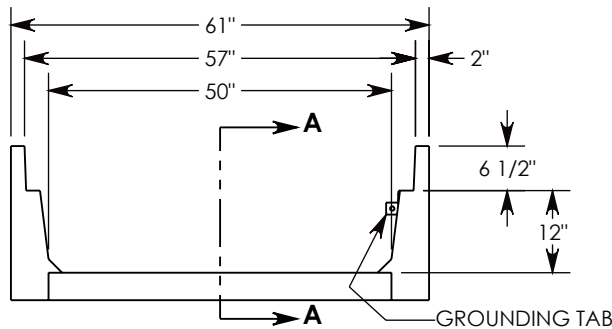
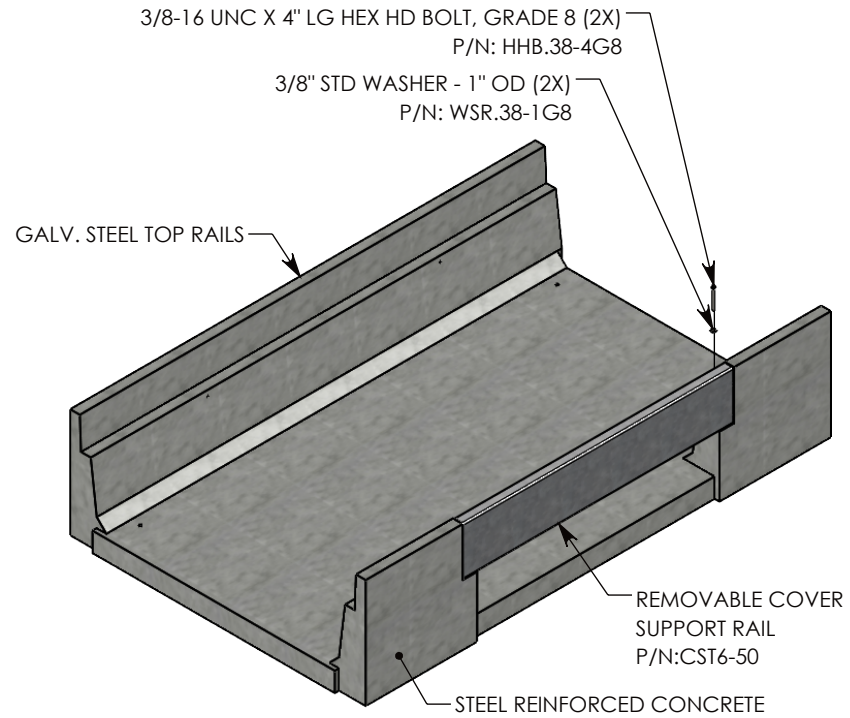
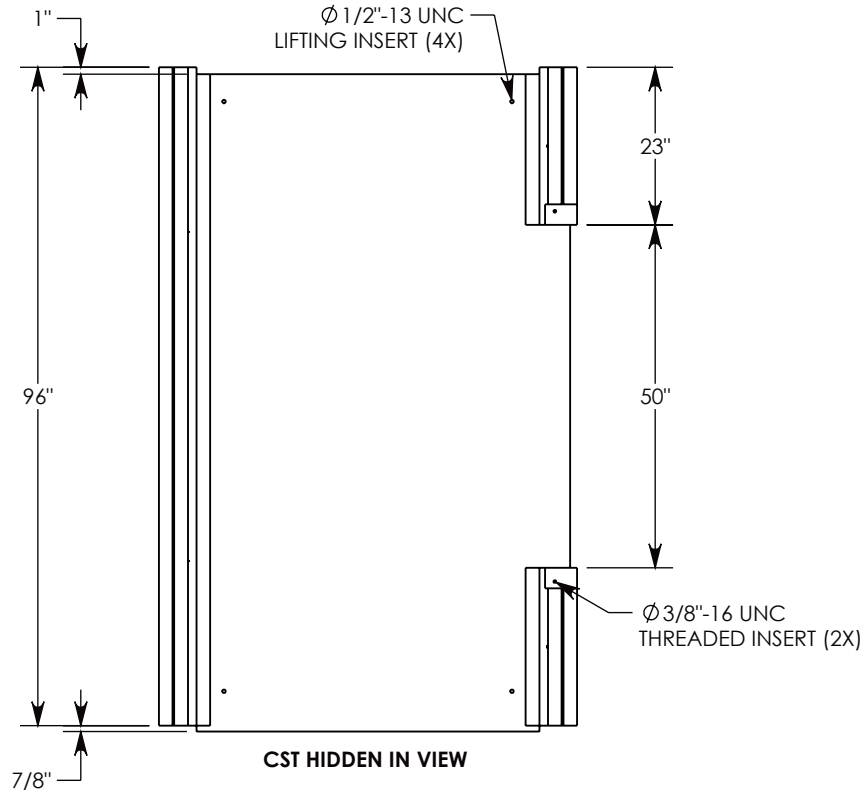

SECTION A-A

MAX AASHTO H-40 RATED - 64,000 LB. SINGLE AXLE LOAD.
DEPENDENT ON TRENCH COVER RATING

DRAWN BY: ROBIN LEWIS

CREATED DATE: 7/14/2008 **REVISION LEVEL: B**

SAVED DATE: 9/19/2023 **SAVED BY: scallahan**

WEIGHT: 2874 LBS. **MATERIAL: NOTED**

1010 NORTH STAR DRIVE
P.O. BOX 69
ZUMBROTA, MN 55992-0069

DESCRIPTION:

HEAVY TRAFFIC UNIVERSAL CHANNEL

DIMENSIONS ARE IN INCHES
TOLERANCES:
FRACTIONAL: ± 1/8"
ANGULAR: ± 2°

CONTACT INFORMATION:
EMAIL: INFO@CONCASTINC.COM
PHONE: (507) 732-4095
FAX: (507) 732-4094

SHEET 1 OF 1

PART NUMBER:

8852HT (50X0)