

- 1/2-13 UNC X 1" LG HEX HD BOLT
P/N: HHB.5-1 (2X)
- 4" HOLD-DOWN CLAMP
P/N: HDC-1 (2X)
- 1/2-13 UNC SPRING NUT
P/N: USN-.5 (2X)
- 4" LONG X 7/8" DEEP UNISTRUT
P/N: UNST4 (2X)

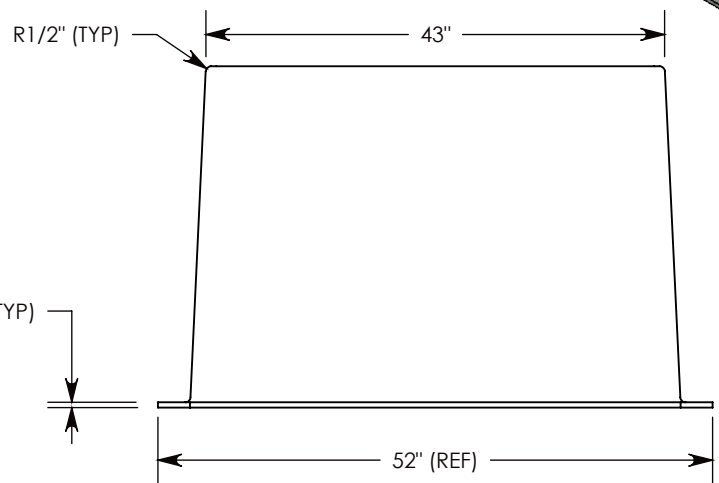

IF SPECIFIC INSERTS OR MOUNTING HARDWARE ARE REQUIRED, PLEASE SPECIFY WHEN ORDERING.

DRAWN BY: ROBIN FLINT	
DATE: 9/21/2017	REVISION LEVEL: 0
WEIGHT: 422 LBS.	MATERIAL: FIBERCRETE

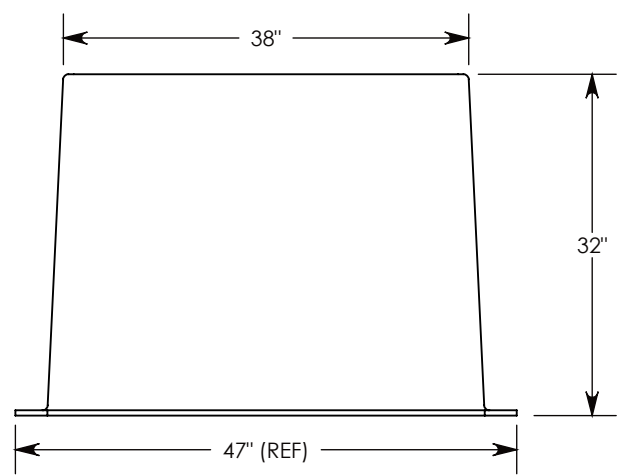
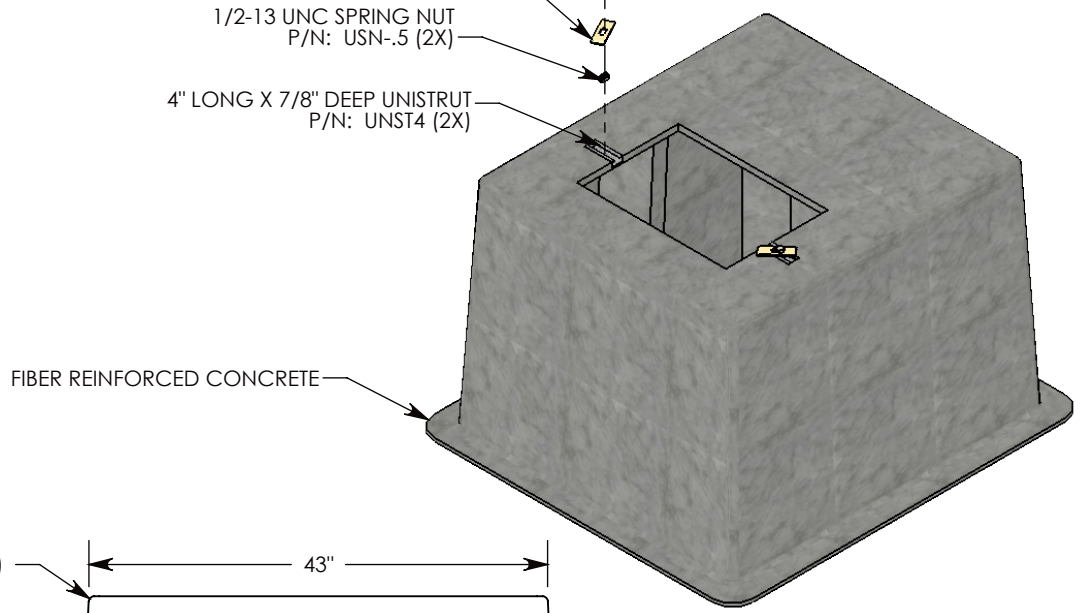

1010 NORTH STAR DRIVE
P.O. BOX 69
ZUMBROTA, MN 55992-0069

DESCRIPTION:		
FIBERCRETE BOX PAD		
DIMENSIONS ARE IN INCHES TOLERANCES: FRACTIONAL: ± 1/8" ANGULAR: ± 2°	CONTACT INFORMATION: EMAIL: INFO@CONCASTINC.COM PHONE: (507) 732-4095 FAX: (507) 732-4094	SHEET 1 OF 1
PART NUMBER: FC-38-43-32-2215 (7)		