

**FIBERCRETE**<sup>®</sup>

FIBER REINFORCED CONCRETE

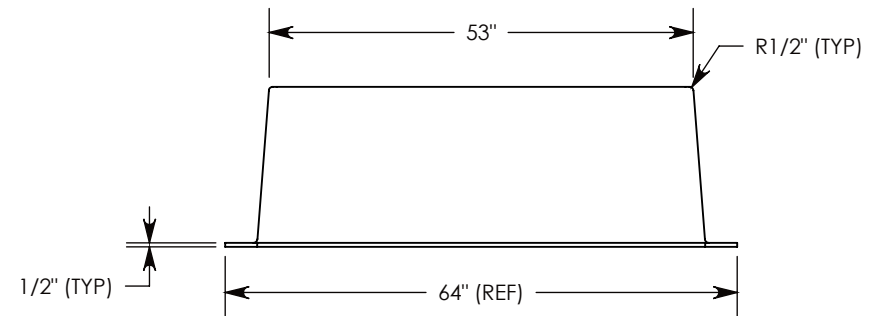
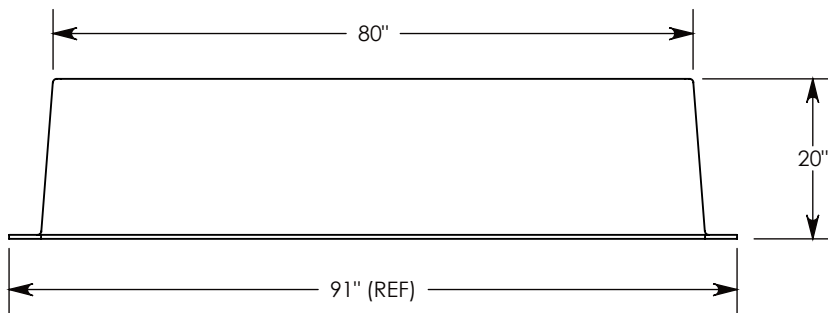
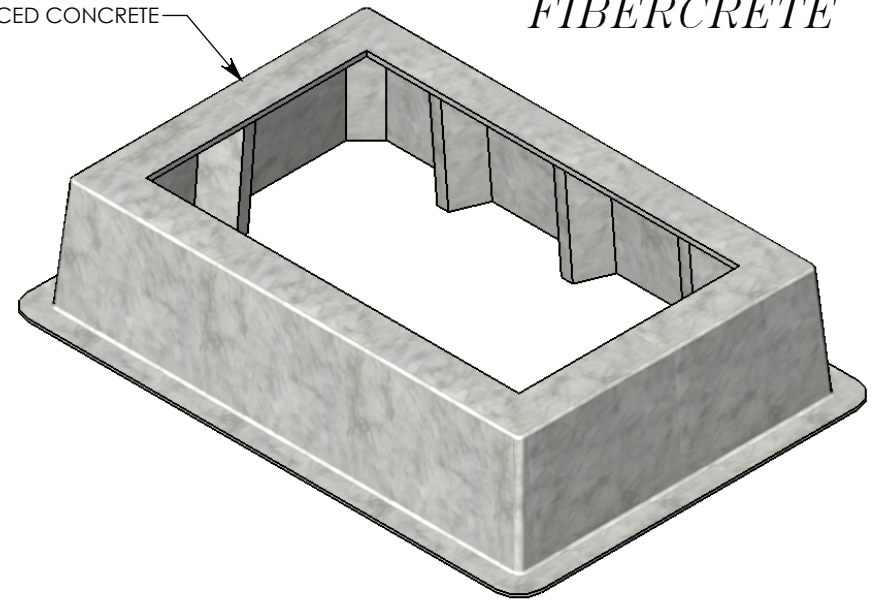
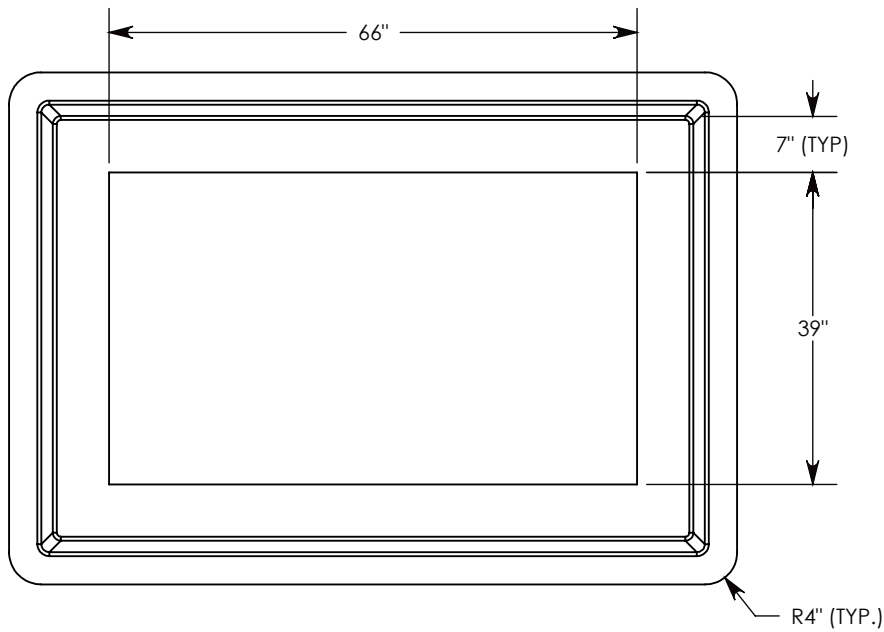

**DRAWN BY: ROBIN FLINT**

**DATE: 2/3/2012**

**REVISION LEVEL: 0**

**WEIGHT:**

**488 LBS.**

**MATERIAL:**

**FIBERCRETE FC**



1010 NORTH STAR DRIVE  
P.O. BOX 69  
ZUMBROTA, MN 55992-0069

**DESCRIPTION:**

**FIBERCRETE BOX PAD**

DIMENSIONS ARE IN INCHES  
TOLERANCES:  
FRACTIONAL:  $\pm 1/8"$   
ANGULAR:  $\pm 2^\circ$

CONTACT INFORMATION:  
EMAIL: [INFO@CONCASTINC.COM](mailto:INFO@CONCASTINC.COM)  
PHONE: (507) 732-4095  
FAX: (507) 732-4094

SHEET 1 OF 1

**PART NUMBER:**

**FC-53-80-20-3966C**