

FIBERCRETE®

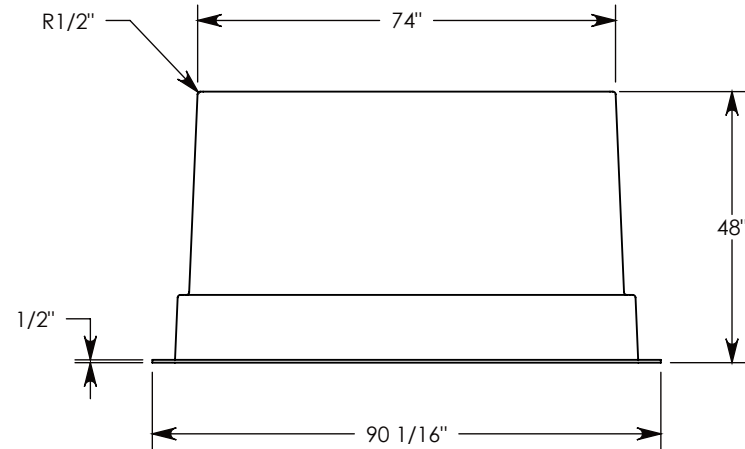
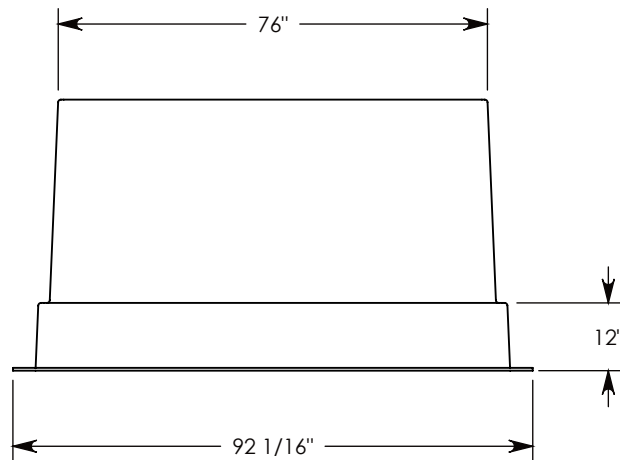
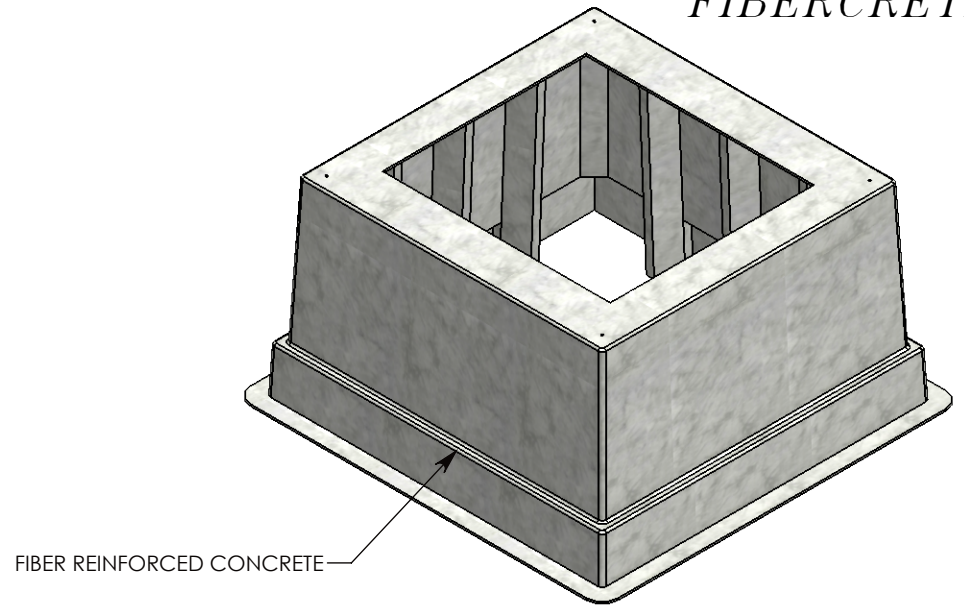
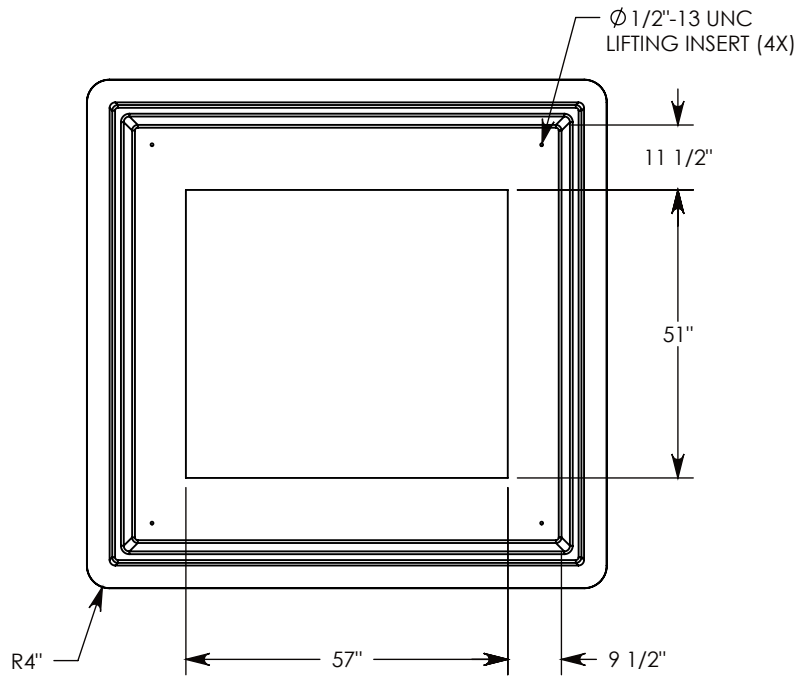

NOTE 1: IF SPECIFIC INSERTS OR MOUNTING HARDWARE ARE REQUIRED, PLEASE SPECIFY WHEN ORDERING.

DRAWN BY: **JESSE GUTTING**

CREATED DATE: **10/2/2020** REVISION LEVEL: **0**

SAVED DATE: **10/2/2020** SAVED BY: **jgutting**

WEIGHT: **1207 LBS.** MATERIAL: **FIBERCRETE FC**

CONCAST
1010 NORTH STAR DRIVE
P.O. BOX 69
ZUMBROTA, MN 55992-0069

DESCRIPTION:

FIBERCRETE PAD BOX

DIMENSIONS ARE IN INCHES
TOLERANCES:
FRACTIONAL: ± 1/8"
ANGULAR: ± 2°

CONTACT INFORMATION:
EMAIL: INFO@CONCASTINC.COM
PHONE: (507) 732-4095
FAX: (507) 732-4094

SHEET 1 OF 1

PART NUMBER:

FC-74-76-48-5157C