

FIBERCRETE[®]

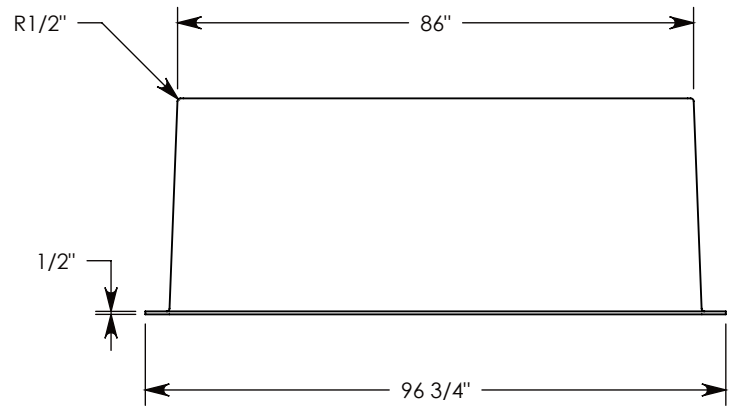

NOTE 1: Ø 1/2"-13 UNC LIFTING INSERTS WILL BE CAST INTO BOX PAD
IF SPECIFIC INSERTS OR MOUNTING HARDWARE ARE REQUIRED, PLEASE SPECIFY WHEN ORDERING

DRAWN BY: JESSE GUTTING	
DATE: 6/26/2018	REVISION LEVEL: 0
WEIGHT: 1206 LBS.	MATERIAL: FIBERCRETE FC

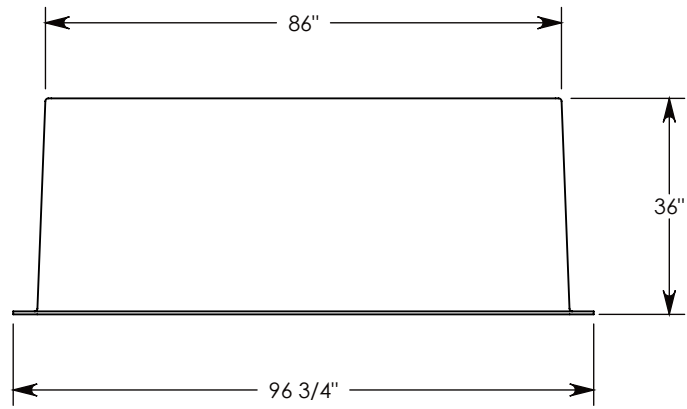
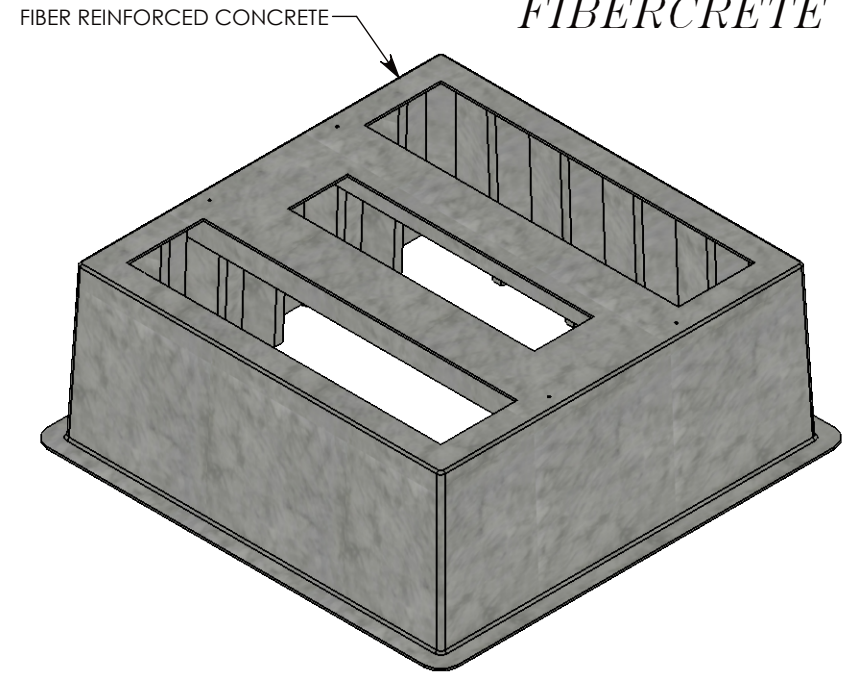
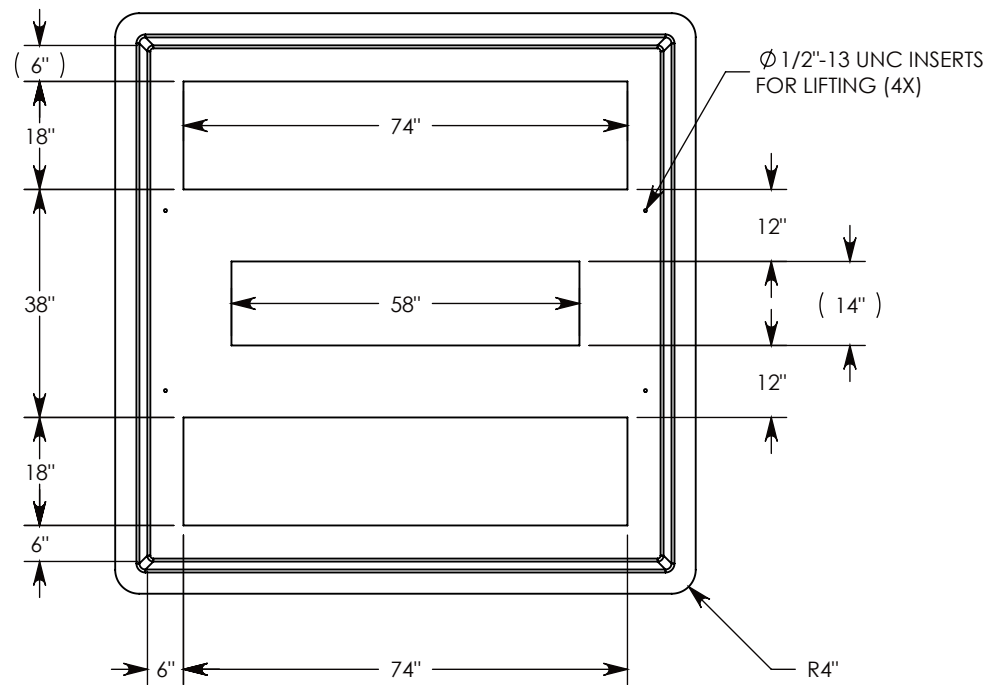

1010 NORTH STAR DRIVE
P.O. BOX 69
ZUMBROTA, MN 55992-0069

DESCRIPTION:		
FIBERCRETE BOX PAD		
DIMENSIONS ARE IN INCHES TOLERANCES: FRACTIONAL: ± 1/8" ANGULAR: ± 2°	CONTACT INFORMATION: EMAIL: INFO@CONCASTINC.COM PHONE: (507) 732-4095 FAX: (507) 732-4094	SHEET 1 OF 1
PART NUMBER: FC-86-86-36(38)2-1874		