

VAULT PACKAGE BILL OF MATERIALS (BOM)

PART NUMBER	DESCRIPTION	QTY
FCV-120-114-76-SS	VAULT WITH STAINLESS STEEL HARDWARE	1
FCV-120-114-SA-LK	SPRING-ASSISTED STEEL COVER WITH STD. DECK PLATE & PADLOCK PROVISION	2

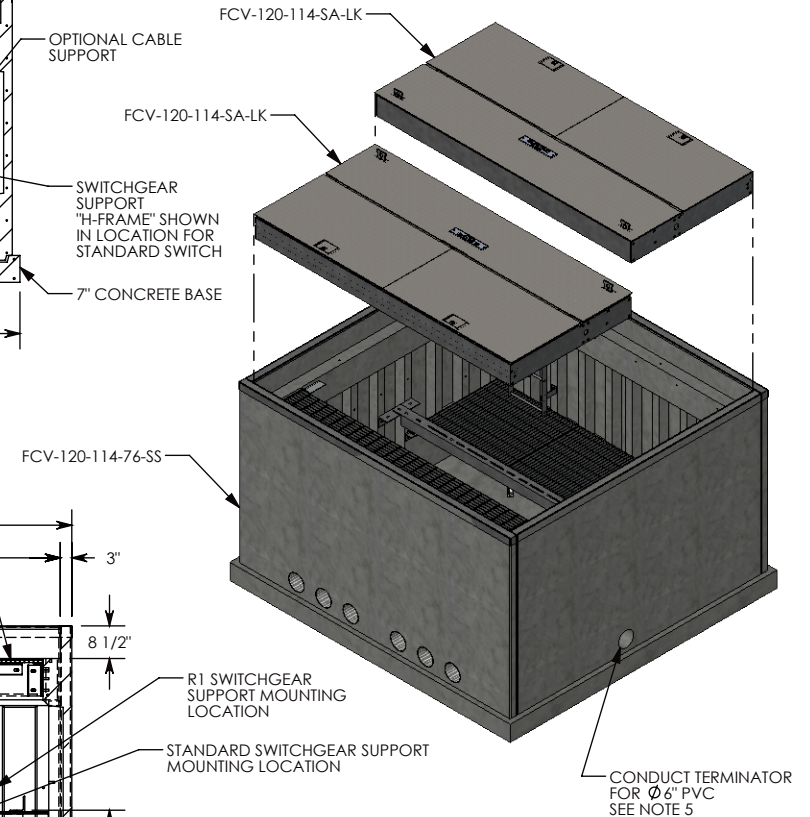
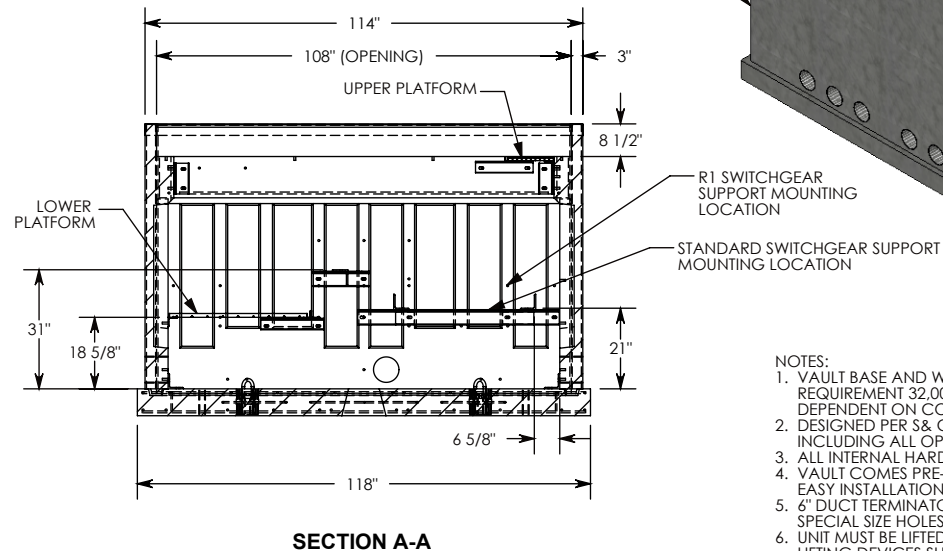
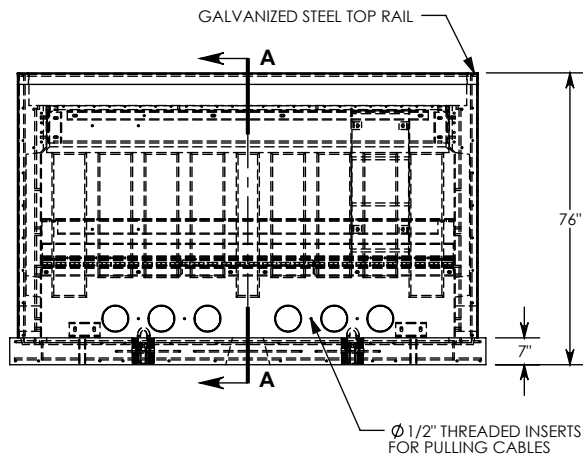
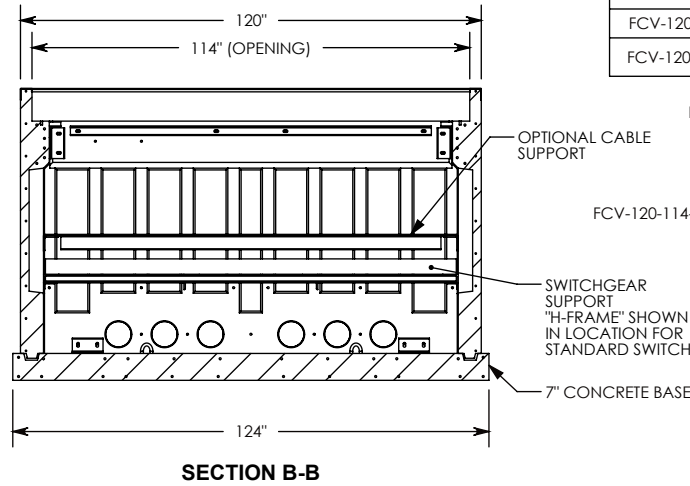
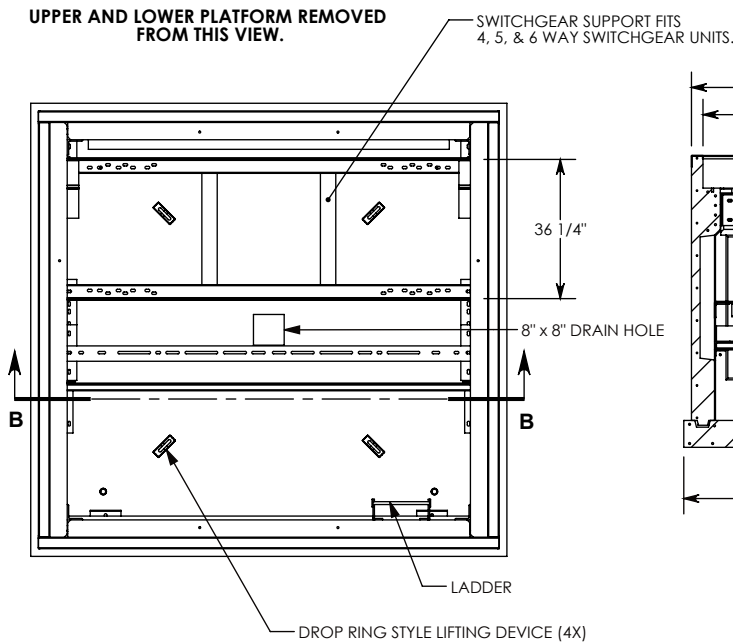

NOTES:

1. VAULT BASE AND WALLS MEET AASHTO H-20 HEAVY EQUIPMENT REQUIREMENT 32,000 LB. AXLE LOAD. OVERALL VAULT RATING DEPENDENT ON COVERS.
2. DESIGNED PER S & C PULL BOX SPECIFICATIONS DATA SHEET 681-51. INCLUDING ALL OPTIONAL INTERIOR STEEL HARDWARE.
3. ALL INTERNAL HARDWARE IS STAINLESS STEEL.
4. VAULT COMES PRE-ASSEMBLED WITH COVERS REMOVED FOR EASY INSTALLATION OF YOUR SWITCHGEAR.
5. 6" DUCT TERMINATORS CAST INTO THE WALLS ARE TYPICAL, BUT ANY SPECIAL SIZE HOLES OR KNOCKOUTS CAN BE ORDERED.
6. UNIT MUST BE LIFTED VIA THE FOUR CAST-IN, DROP RING LIFTING DEVICES SHOWN.
7. LISTED WEIGHT IS THE ASSEMBLED VAULT WITH THE COVERS.

DRAWN BY: **JESSE GUTTING**

CREATED DATE: **10/20/2009** REVISION LEVEL: **0**

SAVED DATE: **3/24/2020** SAVED BY: **jgutting**

WEIGHT: **24278 LBS.** MATERIAL: **NOTED**



DESCRIPTION:

PRECAST CONCRETE VAULT

DIMENSIONS ARE IN INCHES
 TOLERANCES:
 FRACTIONAL: ± 1/8"
 ANGULAR: ± 2°

CONTACT INFORMATION:
 EMAIL: INFO@CONCASTINC.COM
 PHONE: (507) 732-4095
 FAX: (507) 732-4094

SHEET 1 OF 4

PART NUMBER:

FCV-120-114-76-SS4

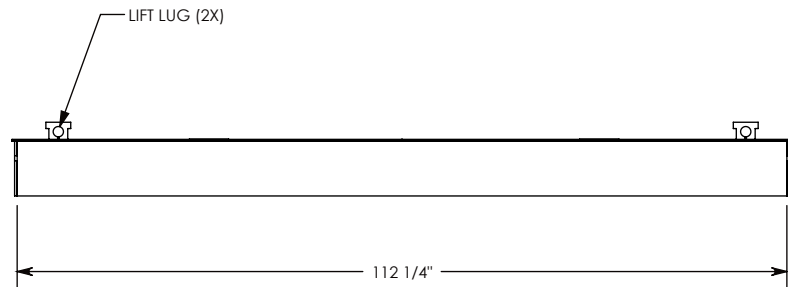
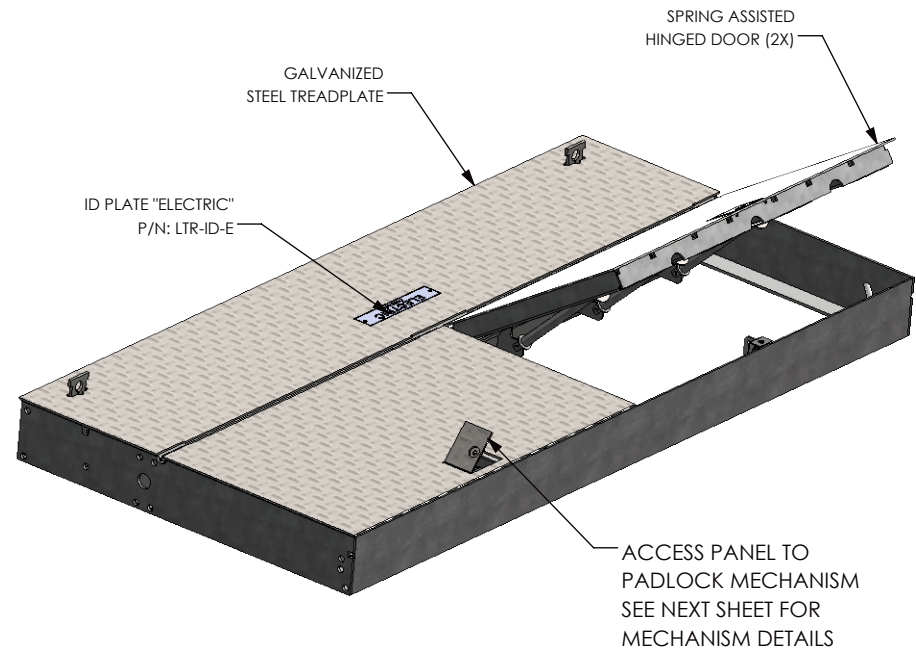
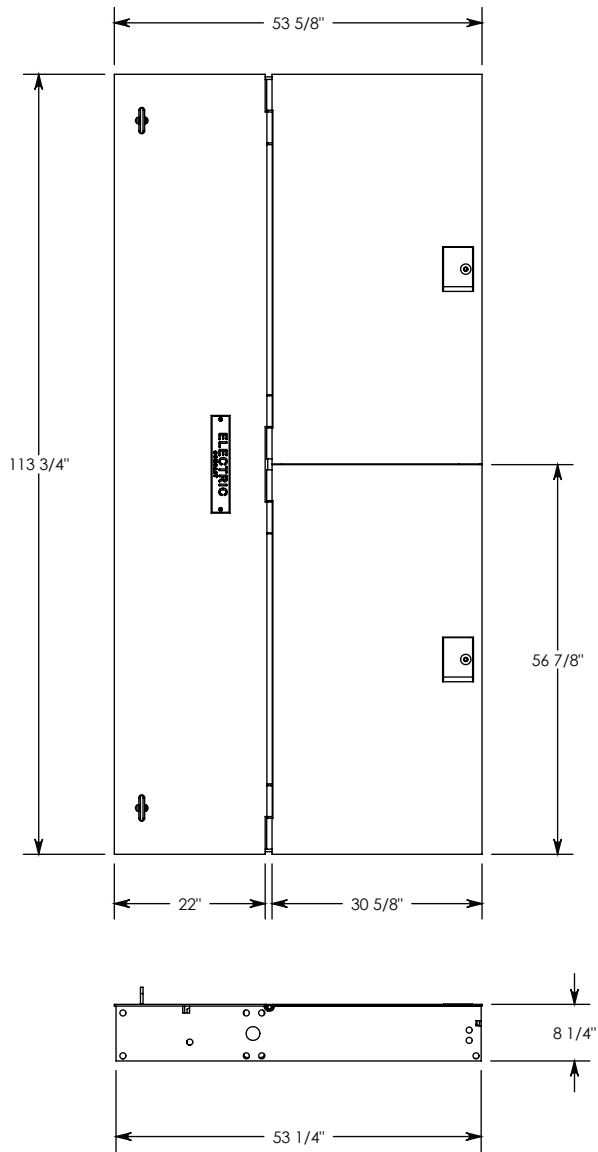

NOTE 1: COVER FITS A 120 - 114 VAULT (OPENING SIZE = 114" X 108")

AASHTO H-20 RATED – 32,000 LB. SINGLE AXLE LOAD

DRAWN BY: JESSE GUTTING	
CREATED DATE: 10/20/2009	REVISION LEVEL: 0
SAVED DATE: 3/24/2020	SAVED BY: jgutting
WEIGHT: 1446 LBS.	MATERIAL: WELDED GALV. STEEL

1010 NORTH STAR DRIVE
P.O. BOX 69
ZUMBROTA, MN 55992-0069

DESCRIPTION: HINGED VAULT DOUBLE COVER		SHEET 2 OF 4
DIMENSIONS ARE IN INCHES TOLERANCES: FRACTIONAL: ± 1/8" ANGULAR: ± 2°	CONTACT INFORMATION: EMAIL: INFO@CONCASTINC.COM PHONE: (507) 732-4095 FAX: (507) 732-4094	
PART NUMBER: FCV-120-114-SA-LK		

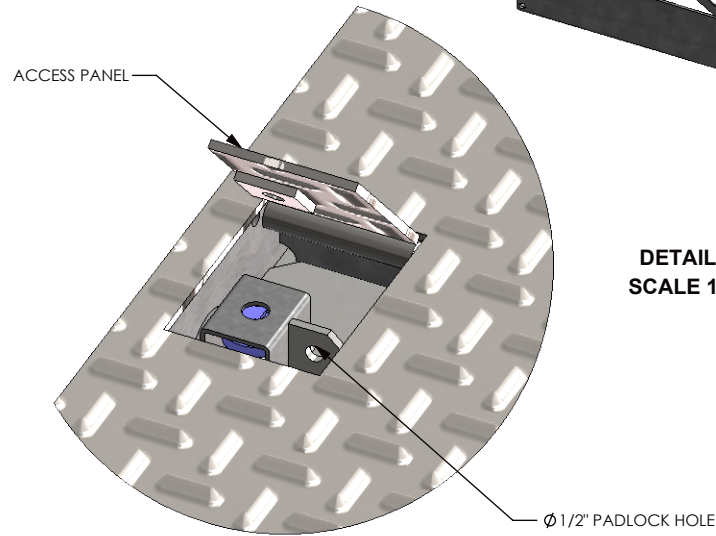
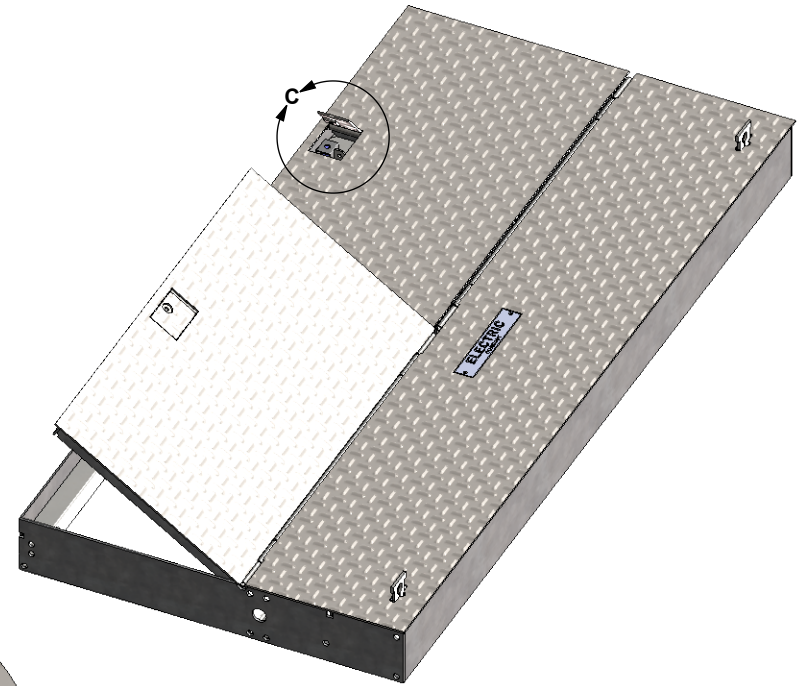
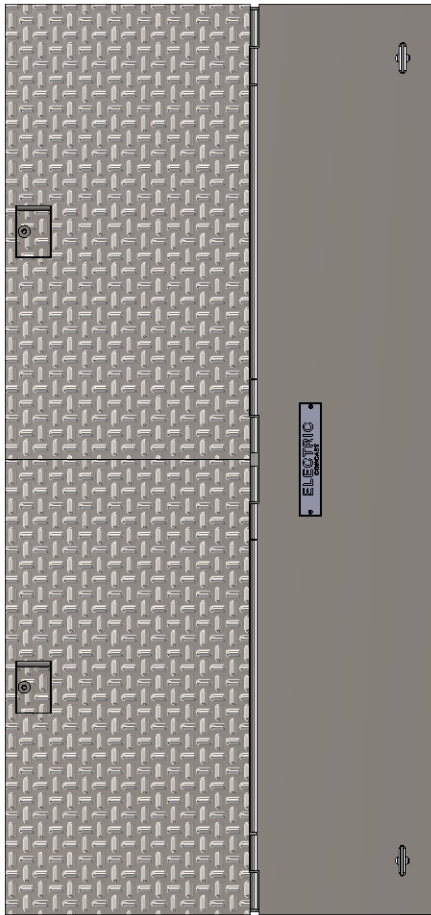

DETAIL C
SCALE 1 : 5

NOTE 1: COVER FITS A 120 - 114 VAULT (OPENING SIZE = 114" X 108")

AASHTO H-20 RATED – 32,000 LB. SINGLE AXLE LOAD

DRAWN BY: JESSE GUTTING	
CREATED DATE: 10/20/2009	REVISION LEVEL: 0
SAVED DATE: 3/24/2020	SAVED BY: jgutting
WEIGHT: 1446 LBS.	MATERIAL: WELDED GALV. STEEL



1010 NORTH STAR DRIVE
P.O. BOX 69
ZUMBROTA, MN 55992-0069

DESCRIPTION: HINGED VAULT DOUBLE COVER		SHEET 3 OF 4
DIMENSIONS ARE IN INCHES TOLERANCES: FRACTIONAL: ± 1/8" ANGULAR: ± 2°	CONTACT INFORMATION: EMAIL: INFO@CONCASTINC.COM PHONE: (507) 732-4095 FAX: (507) 732-4094	
PART NUMBER: FCV-120-114-SA-LK		