

DETAIL B  
SCALE 1 : 12

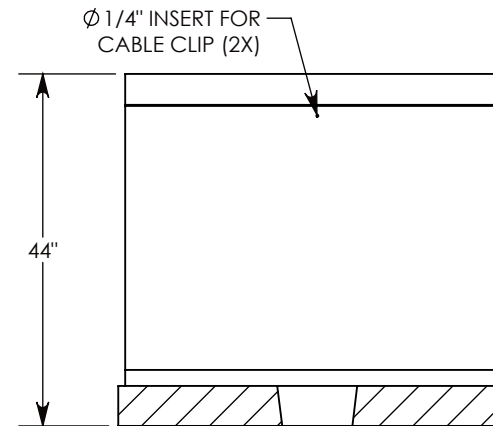
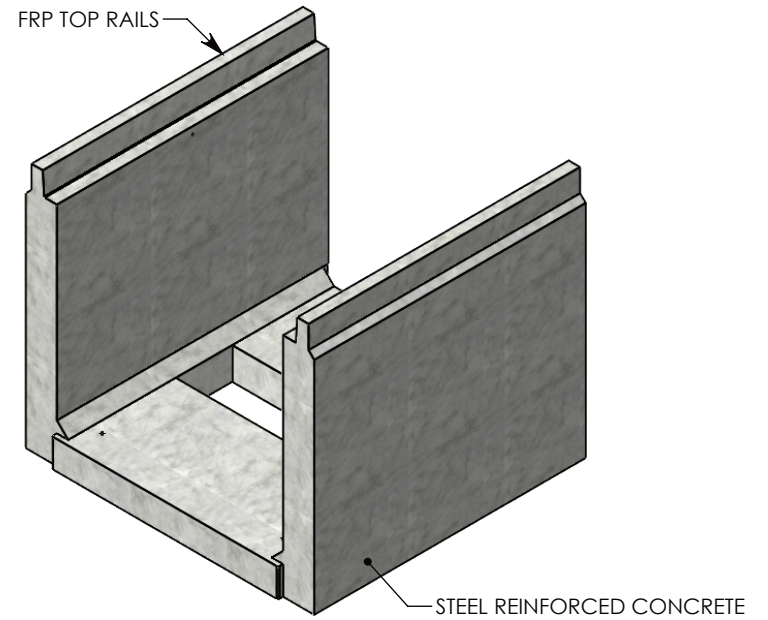

SECTION A-A

NOTE 1: FOR NON-STANDARD LENGTHS, THE CHANNEL WILL BE SOLID BOTTOM AND DESIGNATED WITH ITS CORRESPONDING LENGTH MEASUREMENT. IE: HT4F4036 32"

AASHTO H-20 RATED – 32,000 LB. SINGLE AXLE LOAD

<b>DRAWN BY: SAMUEL CALLAHAN</b>	
<b>CREATED DATE: 4/19/2018</b>	<b>REVISION LEVEL: A</b>
<b>SAVED DATE: 10/20/2020</b>	<b>SAVED BY: scallahan</b>
<b>WEIGHT: 2456 LBS.</b>	<b>MATERIAL: CONCRETE</b>



**CONCAST**  
1010 NORTH STAR DRIVE  
P.O. BOX 69  
ZUMBROTA, MN 55992-0069

<b>DESCRIPTION:</b> <b>HEAVY TRAFFIC CHANNEL</b>		SHEET 1 OF 1
DIMENSIONS ARE IN INCHES TOLERANCES: FRACTIONAL: ± 1/8" ANGULAR: ± 2°	CONTACT INFORMATION: EMAIL: INFO@CONCASTINC.COM PHONE: (507) 732-4095 FAX: (507) 732-4094	
<b>PART NUMBER:</b> <b>HT4F4036 48"</b>		