

FIBERCRETE[®]
TRENCH
SYSTEM

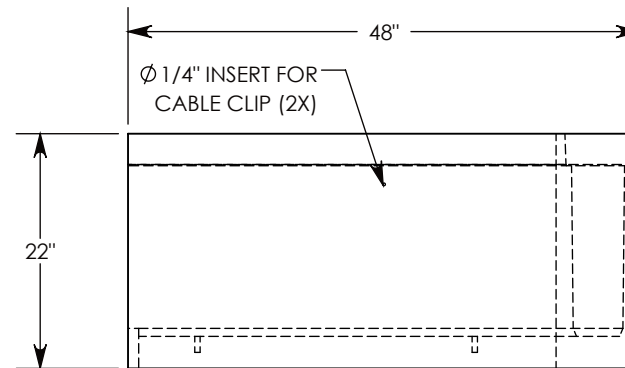
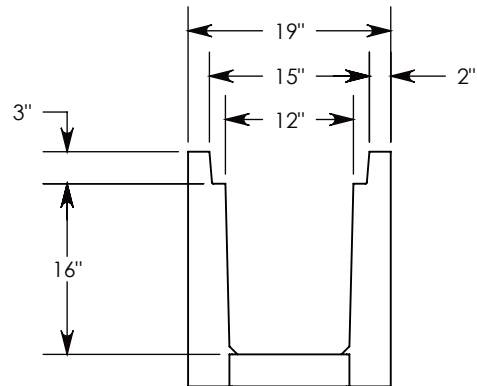
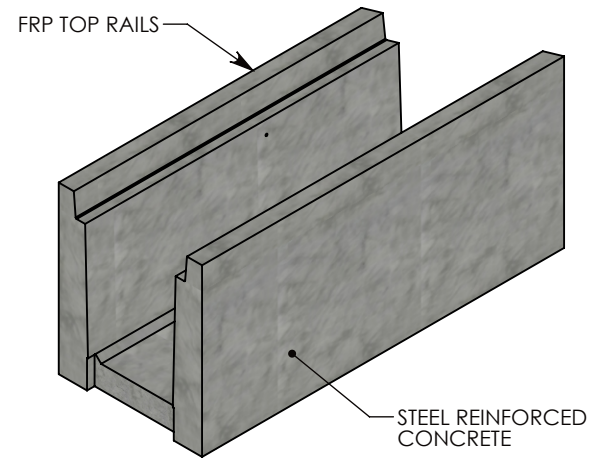
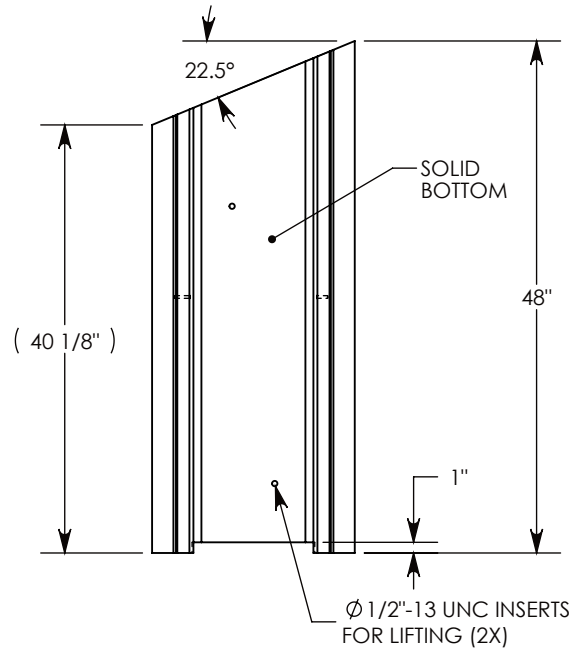

NOTE 1: ALL NON-STANDARD LENGTHS OF CHANNEL WILL BE DESIGNATED WITH ITS CORRESPONDING LENGTH MEASUREMENT. IE: HTF1216 22.5L 32"

AASHTO H-20 RATED – 32,000 LB. SINGLE AXLE LOAD

DRAWN BY: ROSS LAGER

DATE: 1/25/2019

REVISION LEVEL: 0

WEIGHT:

678 LBS.

MATERIAL:

CONCRETE

CONCAST
 1010 NORTH STAR DRIVE
 P.O. BOX 69
 ZUMBROTA, MN 55992-0069

DESCRIPTION:

HEAVY TRAFFIC CHANNEL; 22.5 ANGLE

DIMENSIONS ARE IN INCHES
 TOLERANCES:
 FRACTIONAL: ± 1/8"
 ANGULAR: ± 2°

CONTACT INFORMATION:
 EMAIL: INFO@CONCASTINC.COM
 PHONE: (507) 732-4095
 FAX: (507) 732-4094

SHEET 1 OF 1

PART NUMBER:

HTF1216 22.5L