

REV. A - SIC - 10/8/2020 - ADDED TOP RAIL REDUCTION FEATURE TO CHANGE TOP RAIL TO 2", WAS 3"; REPLACED RIGHT VIEW WITH SECTION A-A; ADDED DETAIL B

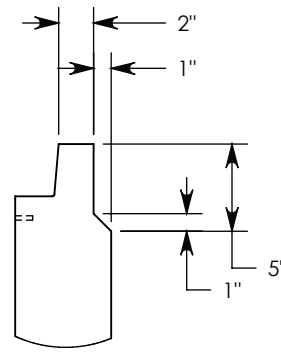

DETAIL B  
SCALE 1 : 11

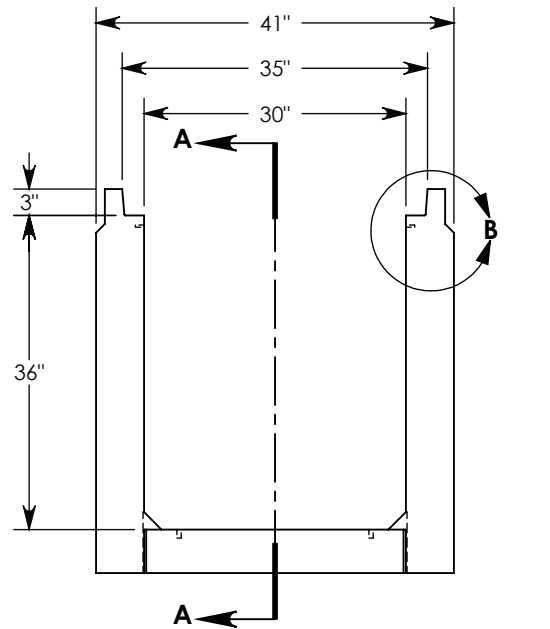
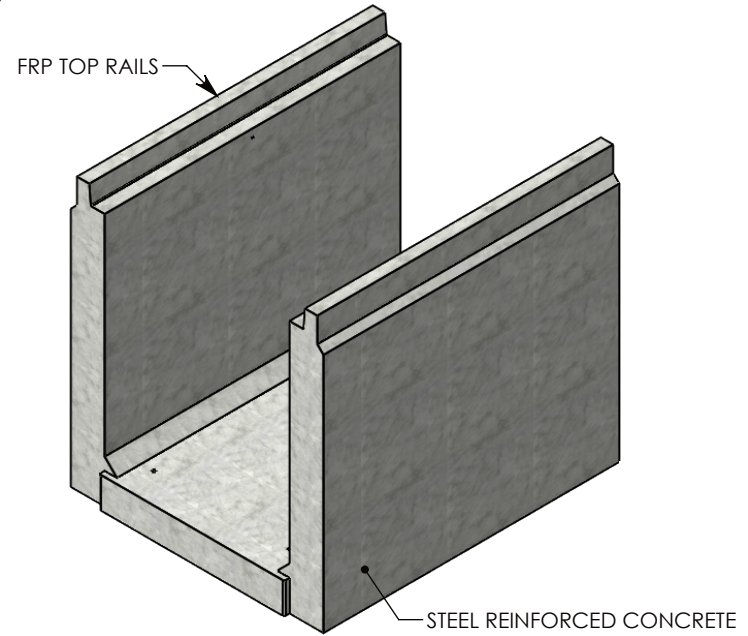
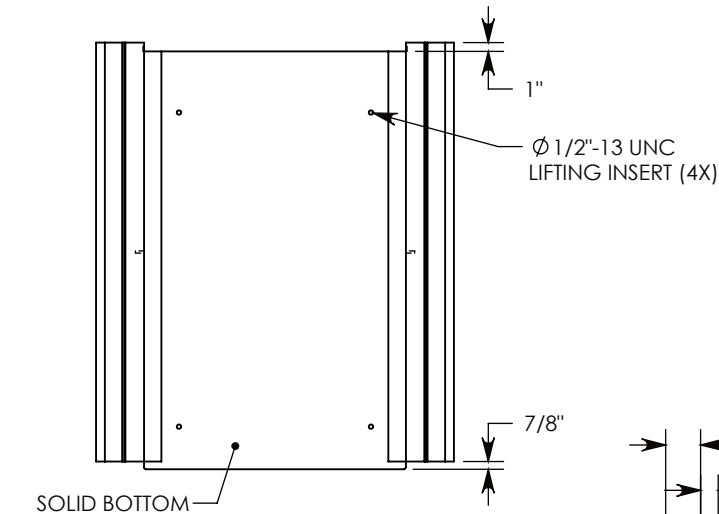
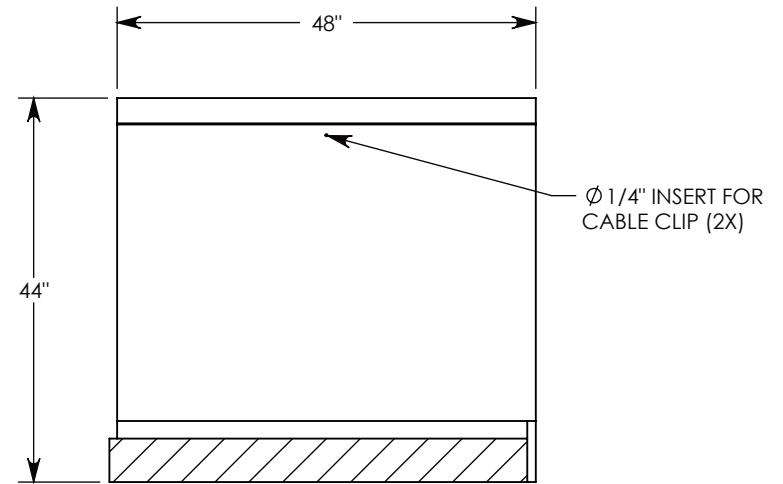

SECTION A-A

NOTE 1: FOR NON-STANDARD LENGTHS THE CHANNEL WILL BE SOLID BOTTOM AND DESIGNATED WITH ITS CORRESPONDING LENGTH MEASUREMENT. IE: HTF3036 36"

AASHTO H-20 RATED – 32,000 LB. SINGLE AXLE LOAD

<b>DRAWN BY: SAMUEL CALLAHAN</b>	
<b>CREATED DATE: 8/15/2019</b>	<b>REVISION LEVEL: A</b>
<b>SAVED DATE: 10/8/2020</b>	<b>SAVED BY: scallahan</b>
<b>WEIGHT: 2415 LBS.</b>	<b>MATERIAL: CONCRETE</b>



1010 NORTH STAR DRIVE  
P.O. BOX 69  
ZUMBROTA, MN 55992-0069

<b>DESCRIPTION:</b> <b>HEAVY TRAFFIC CHANNEL</b>		SHEET 1 OF 1
DIMENSIONS ARE IN INCHES TOLERANCES: FRACTIONAL: ± 1/8" ANGULAR: ± 2°	CONTACT INFORMATION: EMAIL: INFO@CONCASTINC.COM PHONE: (507) 732-4095 FAX: (507) 732-4094	
<b>PART NUMBER:</b> <b>HTF3036SB 48"</b>		