

DETAIL B
SCALE 1 : 13

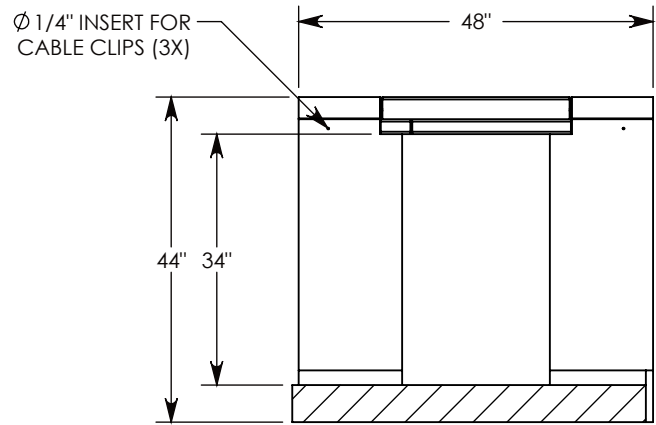
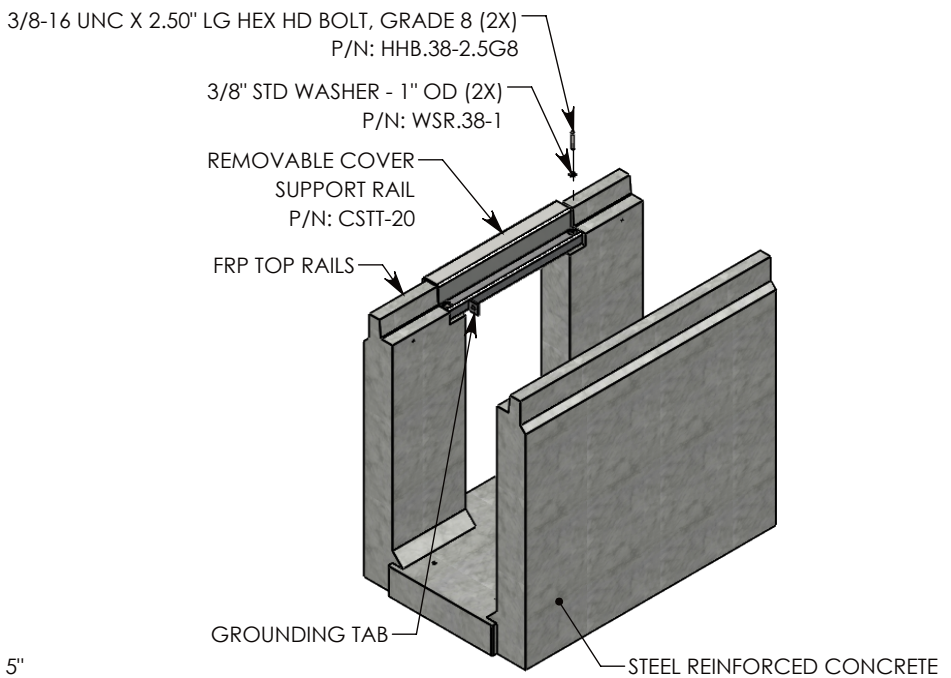

SECTION A-A
AASHTO H-20 RATED - 32,000 LB. SINGLE AXLE LOAD

DRAWN BY: SAMUEL CALLAHAN	
CREATED DATE: 8/28/2019	REVISION LEVEL: A
SAVED DATE: 10/14/2020	SAVED BY: scallahan
WEIGHT: 1898 LBS.	MATERIAL: NOTED

1010 NORTH STAR DRIVE
 P.O. BOX 69
 ZUMBROTA, MN 55992-0069

DESCRIPTION:		
HEAVY TRAFFIC UNIVERSAL CHANNEL		
DIMENSIONS ARE IN INCHES	CONTACT INFORMATION:	
TOLERANCES:	EMAIL: INFO@CONCASTINC.COM	
FRACTIONAL: $\pm 1/8$ "	PHONE: (507) 732-4095	
ANGULAR: $\pm 2^\circ$	FAX: (507) 732-4094	
PART NUMBER:		
HTFU2036 (0X20)		