

DETAIL B
SCALE 1 : 15

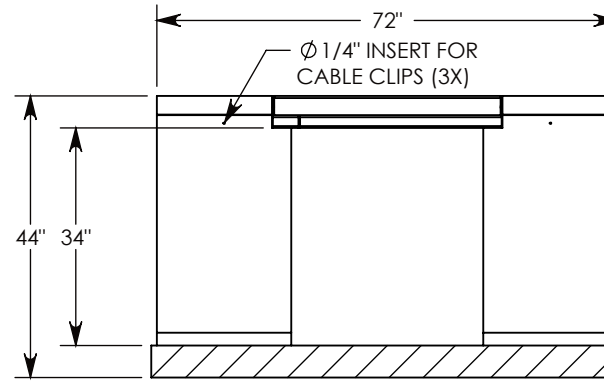
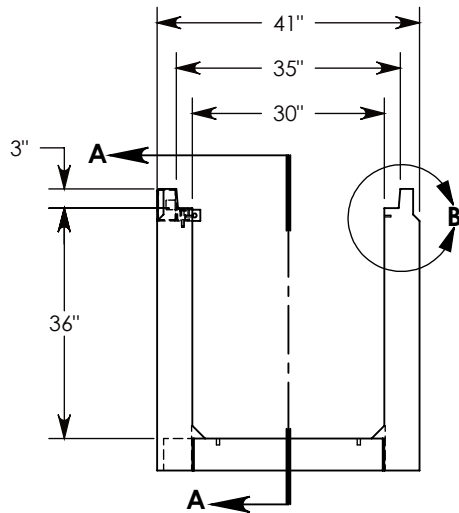

SECTION A-A

AASHTO H-20 RATED - 32,000 LB. SINGLE AXLE LOAD

DRAWN BY: SAMUEL CALLAHAN

CREATED DATE: 8/28/2019 **REVISION LEVEL:** A

SAVED DATE: 10/14/2020 **SAVED BY:** scallahan

WEIGHT: 3142 LBS. **MATERIAL:** NOTED

1010 NORTH STAR DRIVE
 P.O. BOX 69
 ZUMBROTA, MN 55992-0069

DESCRIPTION:
HEAVY TRAFFIC UNIVERSAL CHANNEL

DIMENSIONS ARE IN INCHES
 TOLERANCES:
 FRACTIONAL: $\pm 1/8$ "
 ANGULAR: $\pm 2^\circ$

CONTACT INFORMATION:
 EMAIL: INFO@CONCASTINC.COM
 PHONE: (507) 732-4095
 FAX: (507) 732-4094

SHEET 1 OF 1

PART NUMBER:
HTFU3036 (0X30)