

REV A - MKM - 5/29/18 - UPDATED MODEL & DRAWING
 REV B - MKM - 3/11/19 - UPDATED SURELOCK NOTE

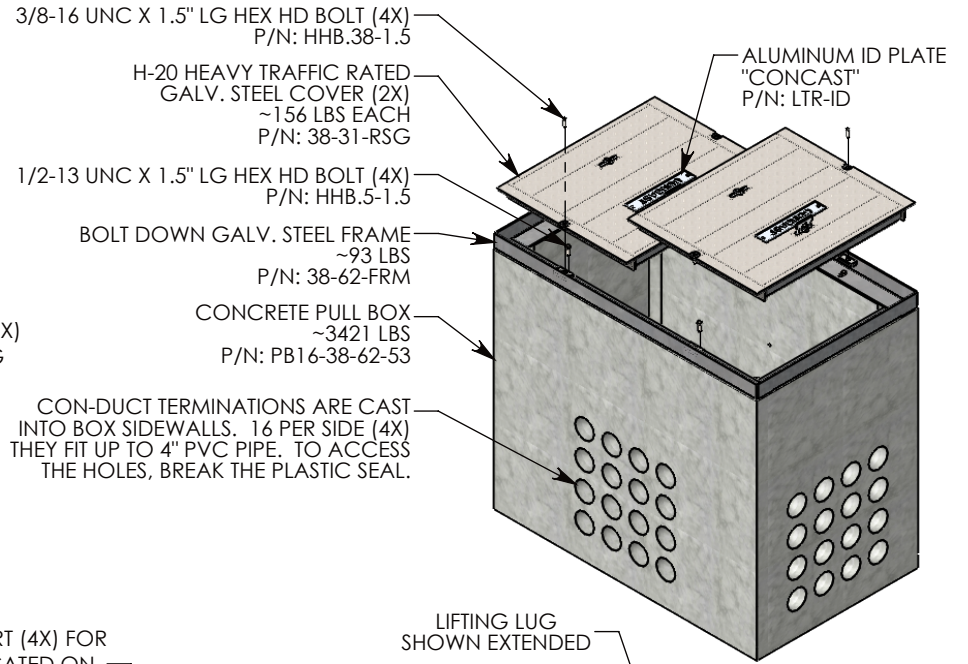

Ø 1/2"-13 UNC INSERT (4X) FOR PULLING EYES. LOCATED ON BOX INTERIOR (1X PER SIDE)

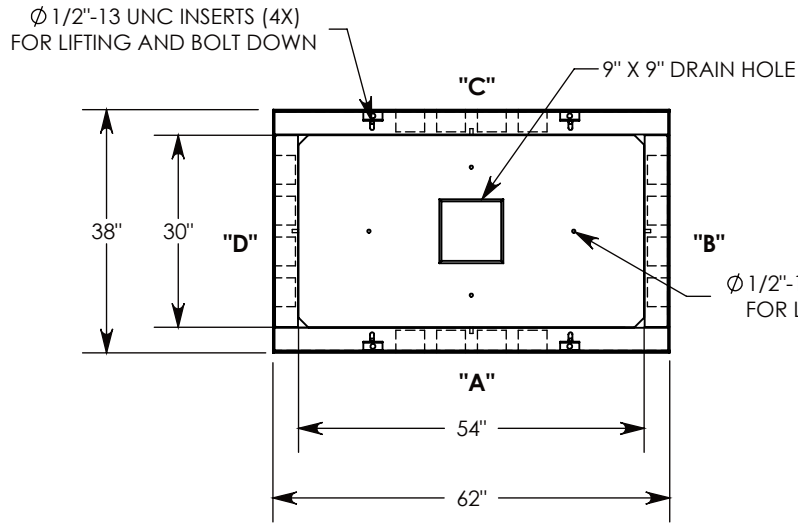
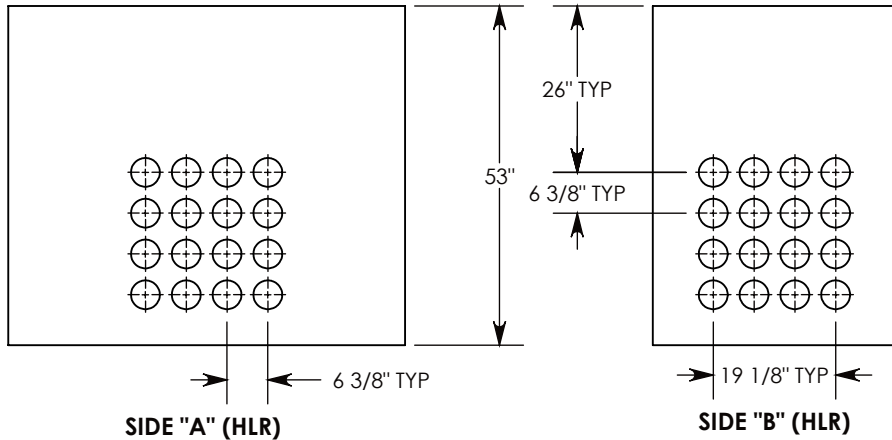
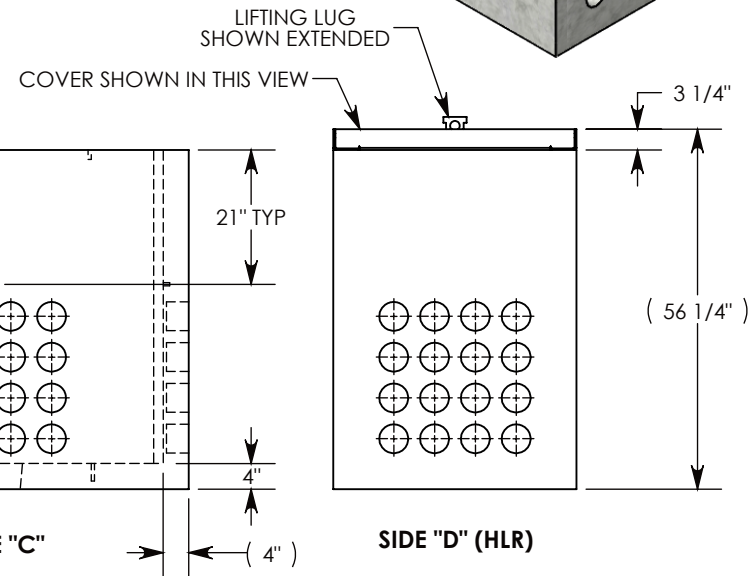

NOTE 1: FOR PVC SIZES SMALLER THAN 4", USE CONCAST RC41 (REDUCING COUPLER)

NOTE 2: FOR ADDED SECURITY, PENTA HEAD (P/N: PTA.38-1.5) OR SURELOCK BOLTS (P/N: SL.38-1.25) CAN BE ADDED

AASHTO H-20 RATED – 32,000 LB. SINGLE AXLE LOAD

DRAWN BY: ROBIN FLINT

DATE: 3/11/2019

REVISION LEVEL: B

WEIGHT:

MATERIAL:

3807 LBS. W/COVER

NOTED



DESCRIPTION:

CONCRETE PULL BOX W/RSG COVERS

DIMENSIONS ARE IN INCHES
 TOLERANCES:
 FRACTIONAL: ± 1/8"
 ANGULAR: ± 2°

CONTACT INFORMATION:
 EMAIL: INFO@CONCASTINC.COM
 PHONE: (507) 732-4095
 FAX: (507) 732-4094

SHEET 1 OF 1

PART NUMBER:

PB16-38-62-53-RSG