

REV A - JCG - 5/14/18 - UPDATED COVER AND BOX HEIGHT  
 REV B - MKM - 3/11/19 - UPDATED SURELOCK NOTE

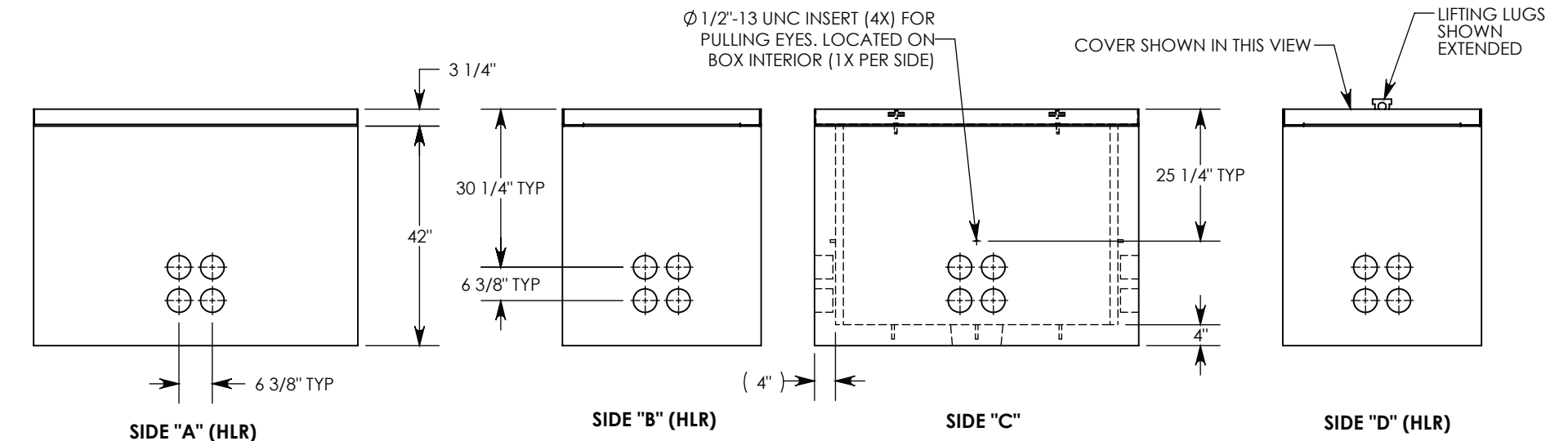
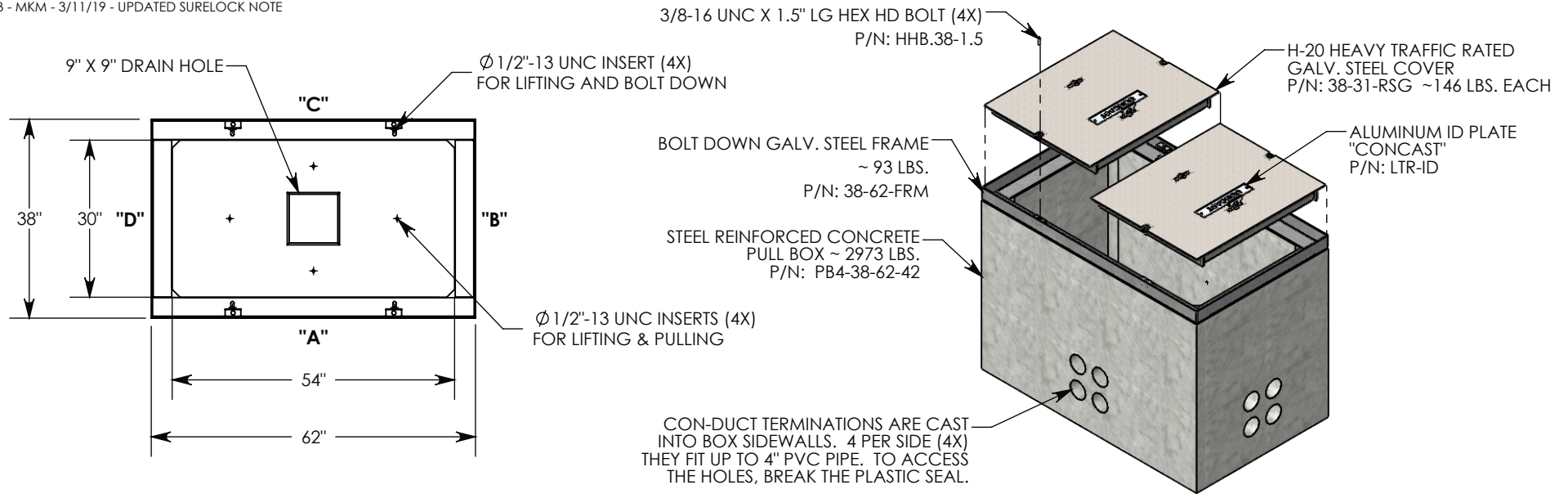

**NOTE 1:** FOR PVC SIZES SMALLER THAN 4", USE CONCAST RC41 (REDUCING COUPLER)  
**NOTE 2:** FOR ADDED SECURITY, PENTA HEAD (P/N: PTA.38-1.5) OR SURELOCK BOLTS (P/N: SL.38-1.25) CAN BE ADDED

AASHTO H-20 RATED – 32,000 LB. SINGLE AXLE LOAD

<b>DRAWN BY: ROBIN FLINT</b>	
<b>DATE: 3/11/2019</b>	<b>REVISION LEVEL: A</b>
<b>WEIGHT: 3359 LBS. W/COVER</b>	<b>MATERIAL: NOTED</b>



1010 NORTH STAR DRIVE  
 P.O. BOX 69  
 ZUMBROTA, MN 55992-0069

<b>DESCRIPTION:</b> <b>CONCRETE PULL BOX W/RSG COVERS</b>		
DIMENSIONS ARE IN INCHES TOLERANCES: FRACTIONAL: ± 1/8" ANGULAR: ± 2°	CONTACT INFORMATION: EMAIL: INFO@CONCASTINC.COM PHONE: (507) 732-4095 FAX: (507) 732-4094	SHEET 1 OF 1
<b>PART NUMBER:</b> <b>PB4-38-62-42-RSG</b>		