

Ø 1/2"-13 UNC INSERT (4X) FOR PULLING EYES. LOCATED ON BOX INTERIOR (1X PER SIDE)

LIFTING LUG SHOWN EXTENDED
COVER SHOWN IN THIS VIEW

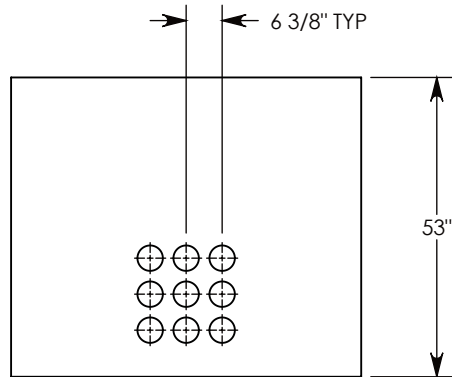

SIDE "A" (HLR)

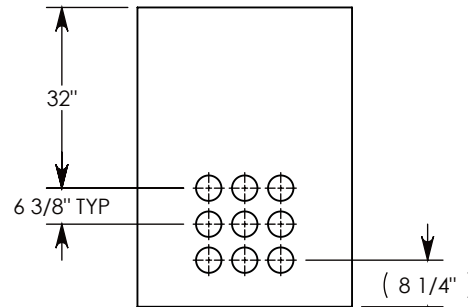

SIDE "B" (HLR)

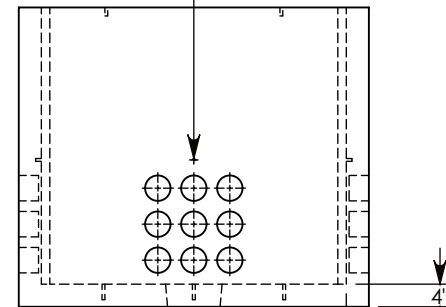

SIDE "C"

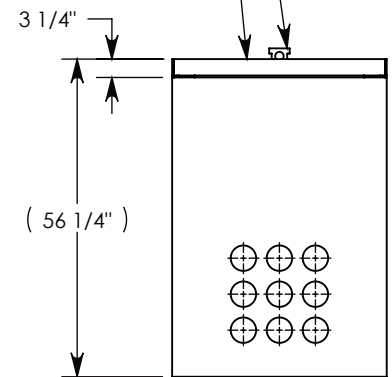

SIDE "D" (HLR)

NOTE 1: FOR PVC SIZES SMALLER THAN 4", USE CONCAST RC41 (REDUCING COUPLER)

AASHTO H-20 RATED – 32,000 LB. SINGLE AXLE LOAD

DRAWN BY: **JESSE GUTTING**

CREATED DATE: **8/19/2020** REVISION LEVEL: **0**

SAVED DATE: **8/20/2020** SAVED BY: **jgutting**

WEIGHT: **3990 LBS.**
MATERIAL: **NOTED**

CONCAST
1010 NORTH STAR DRIVE
P.O. BOX 69
ZUMBROTA, MN 55992-0069

DESCRIPTION:

CONCRETE PULL BOX W/RSGSLP COVERS

DIMENSIONS ARE IN INCHES
TOLERANCES:
FRACTIONAL: ± 1/8"
ANGULAR: ± 2°

CONTACT INFORMATION:
EMAIL: INFO@CONCASTINC.COM
PHONE: (507) 732-4095
FAX: (507) 732-4094

SHEET 1 OF 1

PART NUMBER:

PB9-38-62-53-RSGSLP