

CONCRETE INC.

-PRECISELY ENGINEERED HIGH STRENGTH CONCRETE-



Give new life to old trench systems!
Fibercrete® covers are an attractive and
economical solution to old faulty covers.
Fibercrete® a trusted name since 1969.

Fibercrete®



Many standard sizes available.
Custom sizes also available.
Fibercrete®, Steel, Ventilated, or
Aluminum Construction...

REPLACEMENT COVERS

"We've Got You Covered"

REPLACEMENT COVERS

Fibercrete®

COMMON REPLACEMENT COVER SIZES

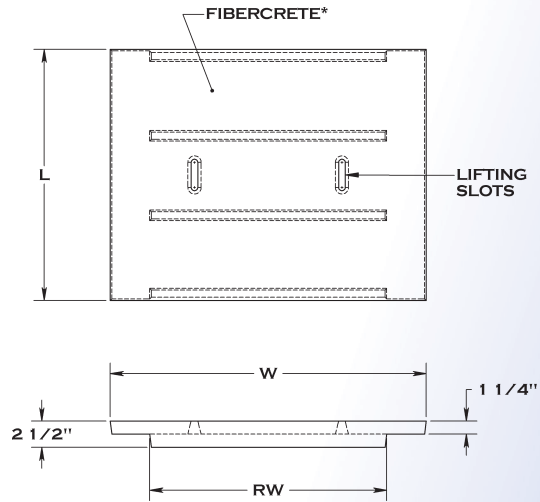

PART NUMBER	WIDTH (W)	LENGTH (L)	RIB WIDTH (RW)	WEIGHT (LBS.)
F20.548 (16.5)	20.5"	48"	16.5"	92
F2830 (21.5)	28"	30"	21.5"	77
F3224 (23)	32"	24"	23"	72
F3230 (25.5)	32"	30"	25.5"	88
F35.524 (22.5)	35.5"	24"	22.5"	80
F3624 (30)	36"	24"	30"	81
F3830 (31.5)	38"	30"	31.5"	105
F4824 (36)	48"	24"	36"	109
F4830 (41.5)	48"	30"	41.5"	137
F5220 (45)	52"	20"	45"	97
F52.524 (40)	52.5"	24"	40"	119
F5724 (37)	57"	24"	37"	129

Chart depicts our most common sizes, other sizes available. Covers are Pedestrian rated 200 lbs./ft².



Covers can be Colored.

- Fibercrete® Covers are ideal for poured in place trench systems.
- Concrete, Steel Galvanized, and Aluminum covers can be designed to meet AASHTO H-10 or H-20 Traffic Ratings for Road Crossing applications.
- Fibercrete® and Concrete Covers can be colored and/or stamped.
- Fibercrete® Covers are light weight, high strength covers that can be lifted by one person.
- Cover layout drawings are available upon request.

CONCAST MAKES IT SIMPLE...

PART #'S: XWL-H (RW)

-Drop the 'RW' if no rib is needed.

-Drop the 'H' for covers that are 1 1/4" High.

W= WIDTH

L= LENGTH

H= HEIGHT

RW= RIB WIDTH

X-OPTIONS:

F= FIBERCRETE®

C= CONCRETE

A= ALUMINUM

SG= STEEL GALVINIZED

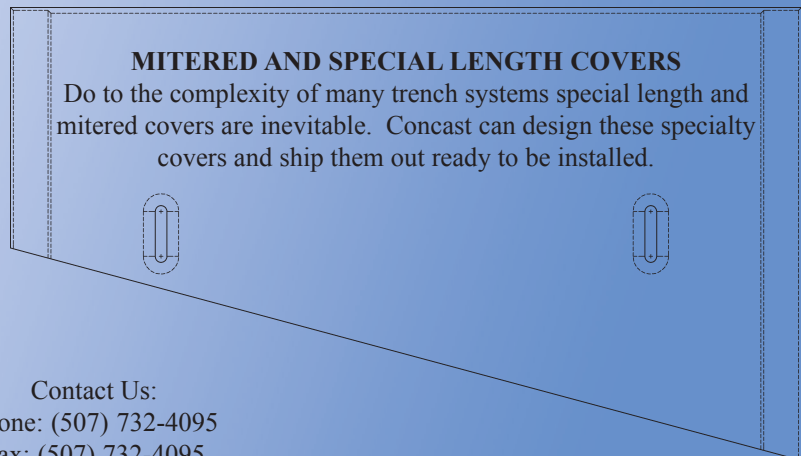

Contact Us:

Phone: (507) 732-4095

Fax: (507) 732-4095

Email: info@concastinc.com

Concast Inc. has specialized in concrete products for the electrical industry since 1969.