

FIBERCRETE®

Ø 1/2"-13 UNC INSERT  
FOR LIFTING (4X)

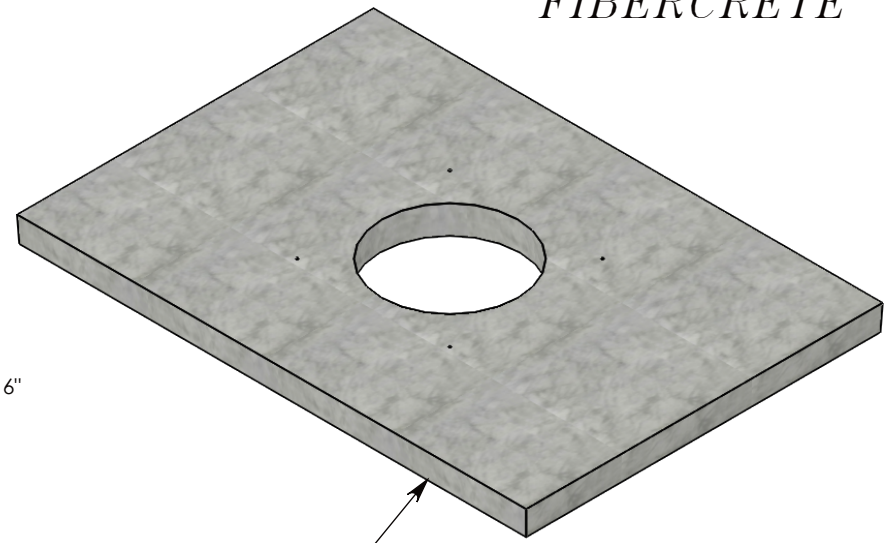

STEEL REINFORCED  
CONCRETE BASE

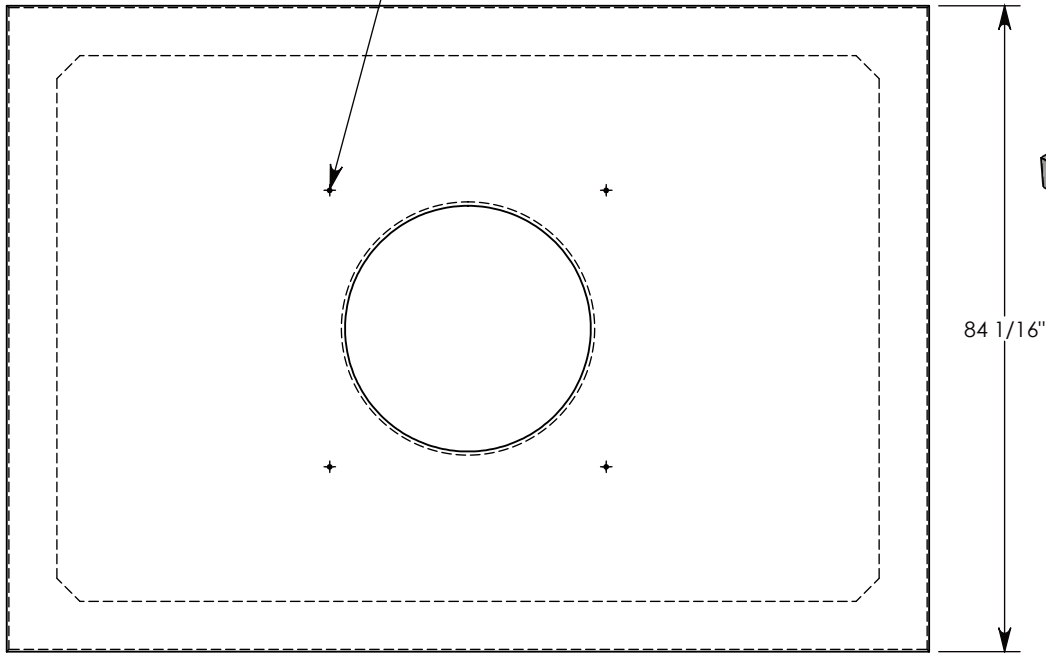
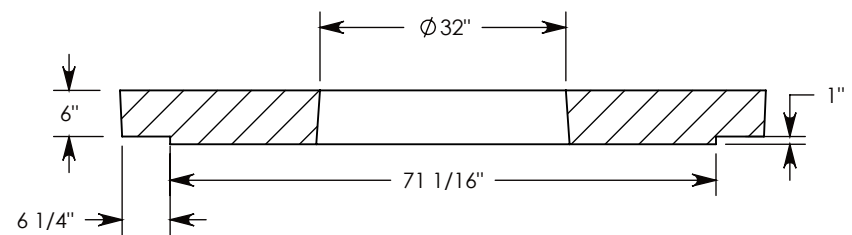
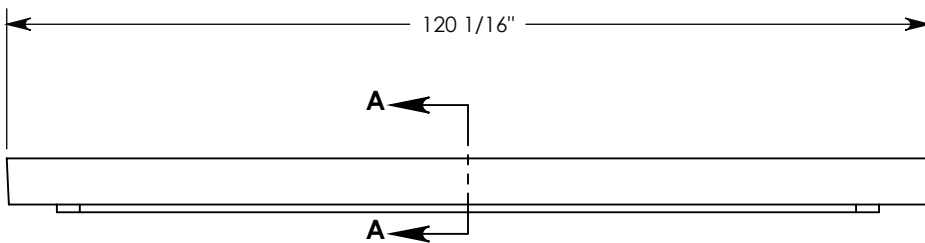

SECTION A-A

**NOTE 1:** USE OPTIONAL 4" TALL EXTENSION/GRADE RINGS TO INCREASE HEIGHT OF COVER OPENING. P/N: HE-42  
**NOTE 2:** CAST IRON MANHOLE LID & FRAME ARE INCLUDED WITH THE FINAL PULL BOX ASSEMBLY.

H-20 RATED - 32,000 LB. PER AXLE LOAD.

|                              |                           |
|------------------------------|---------------------------|
| <b>DRAWN BY: ROBIN FLINT</b> |                           |
| <b>DATE: 9/4/2016</b>        | <b>REVISION LEVEL: A</b>  |
| <b>WEIGHT: 5082 LBS.</b>     | <b>MATERIAL: CONCRETE</b> |



**CONCAST**  
1010 NORTH STAR DRIVE  
P.O. BOX 69  
ZUMBROTA, MN 55992-0069

|                           |                            |              |
|---------------------------|----------------------------|--------------|
| <b>DESCRIPTION:</b>       |                            |              |
| <b>MANHOLE COVER BASE</b> |                            |              |
| DIMENSIONS ARE IN INCHES  | CONTACT INFORMATION:       | SHEET 1 OF 1 |
| TOLERANCES:               | EMAIL: INFO@CONCASTINC.COM |              |
| FRACTIONAL: ± 1/8"        | PHONE: (507) 732-4095      |              |
| ANGULAR: ± 2°             | FAX: (507) 732-4094        |              |
| <b>PART NUMBER:</b>       |                            |              |
| <b>84-120-MH</b>          |                            |              |