

**FIBERCRETE**®

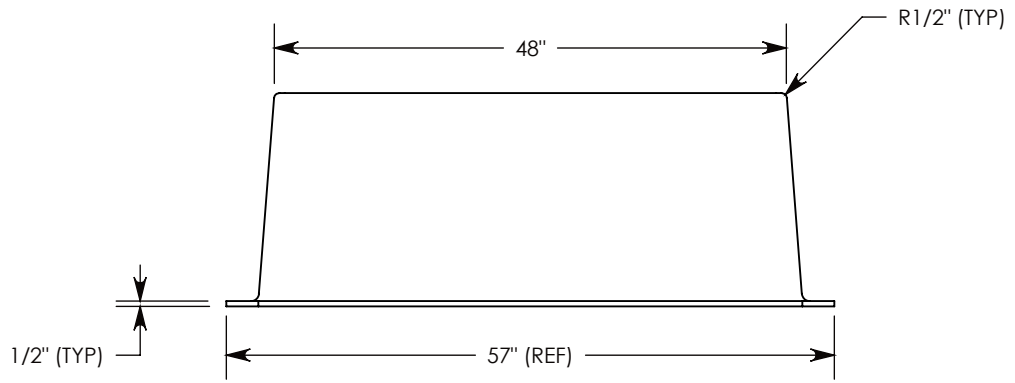

Ø 1/2"-13 UNC LIFTING INSERTS WILL BE CAST INTO BOX PAD  
 IF SPECIFIC INSERTS OR MOUNTING HARDWARE ARE REQUIRED, PLEASE SPECIFY WHEN ORDERING.  
 PART NUMBER IS BASED ON OPENING SIZE. IE: THE SMALLEST OPENING PAD IS P/N: FC-42-48-20-2626 (4)  
 THE LARGEST OPENING PAD IS P/N: FC-42-48-20-3040

<b>DRAWN BY: ROBIN FLINT</b>	
<b>DATE: 5/8/2012</b>	<b>REVISION LEVEL:</b>
<b>WEIGHT:</b>	<b>MATERIAL:</b>
<b>295 LBS.</b>	<b>FIBERCRETE FC</b>

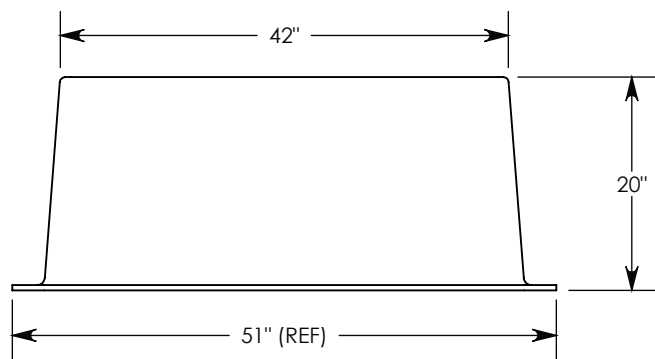

**CONCAST**  
 1010 NORTH STAR DRIVE  
 P.O. BOX 69  
 ZUMBROTA, MN 55992-0069

<b>DESCRIPTION:</b>		
<b>FIBERCRETE BOX PAD</b>		
DIMENSIONS ARE IN INCHES	CONTACT INFORMATION:	SHEET 1 OF 1
TOLERANCES:	EMAIL: INFO@CONCASTINC.COM	
FRACTIONAL: ± 1/8"	PHONE: (507) 732-4095	
ANGULAR: ± 2°	FAX: (507) 732-4094	
<b>PART NUMBER:</b>		
<b>FC-42-48-20-WWLL (X)</b>		