

FIBERCRETE®

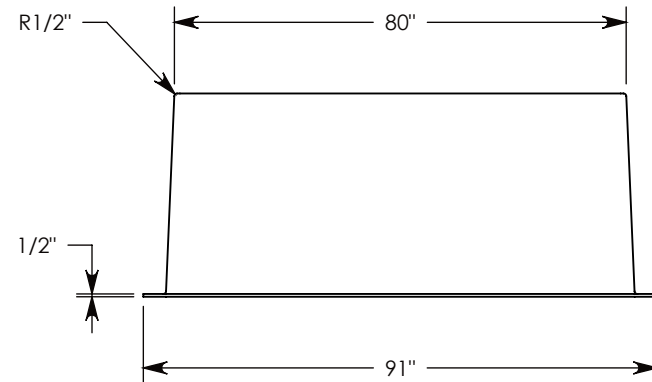
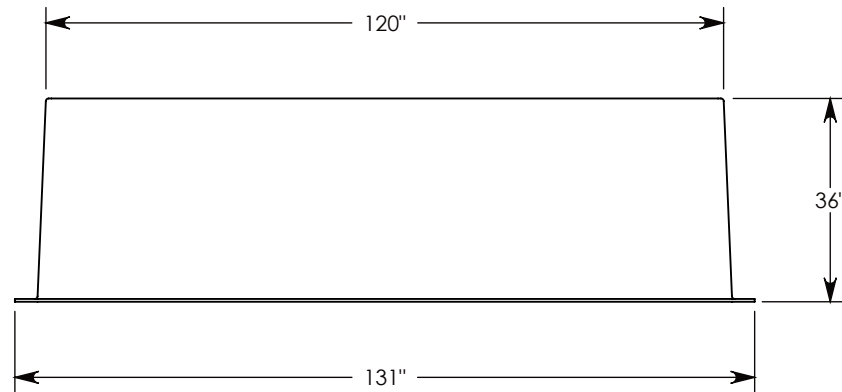
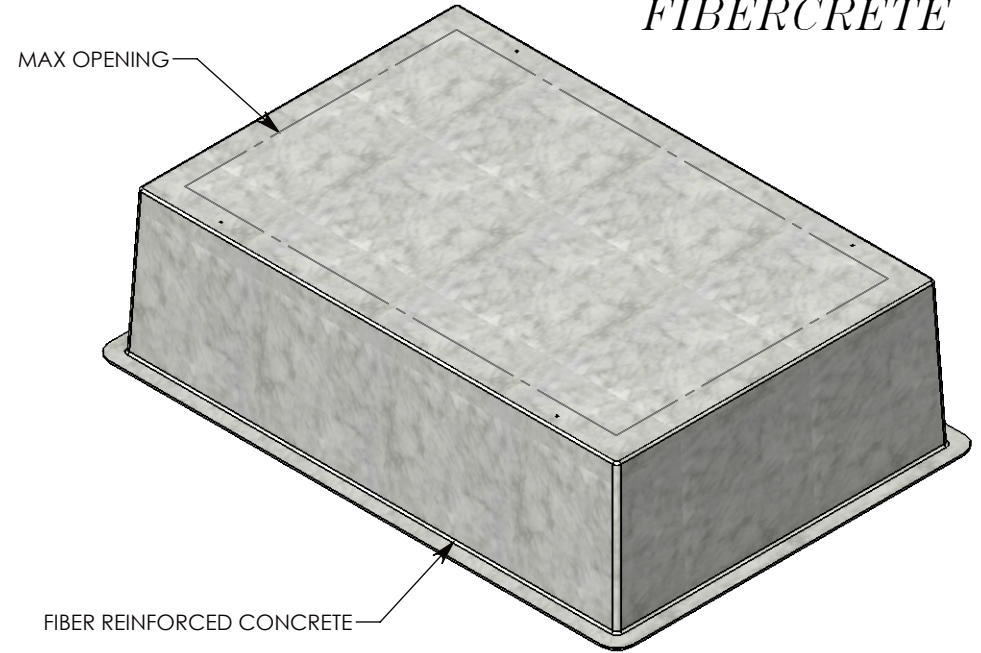
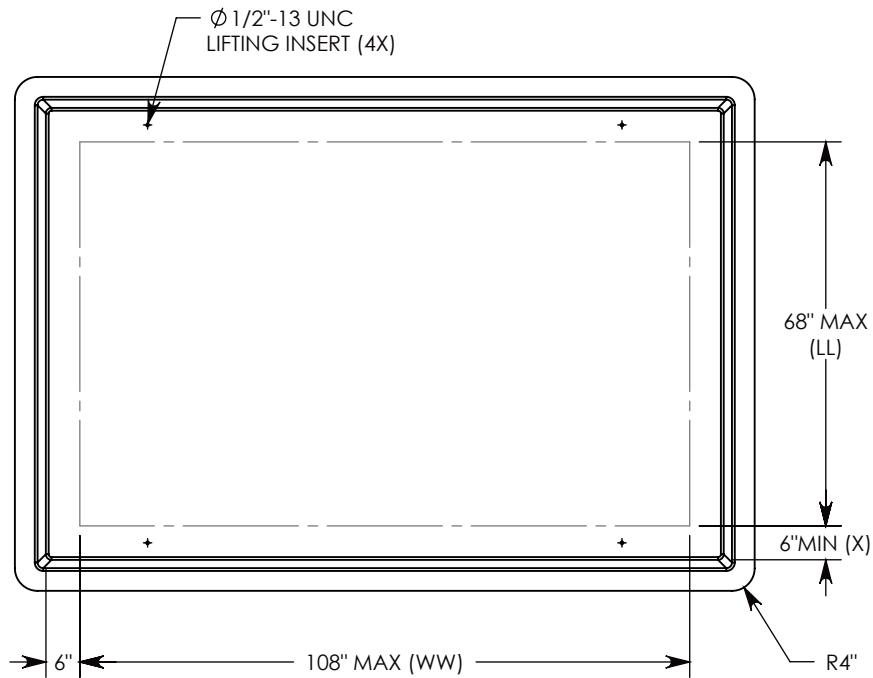

NOTE 1: Ø 1/2"-13 UNC LIFTING INSERTS WILL BE CAST INTO BOX PAD. IF SPECIFIC INSERTS OR MOUNTING HARDWARE ARE REQUIRED, PLEASE SPECIFY WHEN ORDERING

NOTE 2: PART NUMBER IS BASED ON OPENING SIZE. IE: THE LARGEST OPENING PAD IS P/N: FC-80-120-36-68108

NOTE 3: THERE IS NO MINIMUM OPENING

DRAWN BY: **JESSE GUTTING**

CREATED DATE: **9/21/2021** REVISION LEVEL: **0**

SAVED DATE: **9/21/2021** SAVED BY: **jgutting**

WEIGHT: **1583 LBS.** MATERIAL: **FIBERCRETE FC**

CONCAST
 1010 NORTH STAR DRIVE
 P.O. BOX 69
 ZUMBROTA, MN 55992-0069

DESCRIPTION:

FIBERCRETE BOX PAD

DIMENSIONS ARE IN INCHES
 TOLERANCES:
 FRACTIONAL: ± 1/8"
 ANGULAR: ± 2°

CONTACT INFORMATION:
 EMAIL: INFO@CONCASTINC.COM
 PHONE: (507) 732-4095
 FAX: (507) 732-4094

SHEET 1 OF 1

PART NUMBER:

FC-80-120-36-LLWW(X)