

ITEM NO.	PART NUMBER	DESCRIPTION	QTY.
1	CCSCREW-1.25	1/4" X 1.25" LG XCONCRETE SCREW	1
2	8002R-010	TRAFFIC CHANNEL SS CABLE CLIP	1

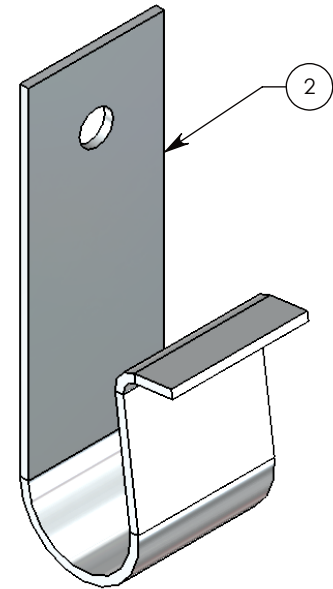
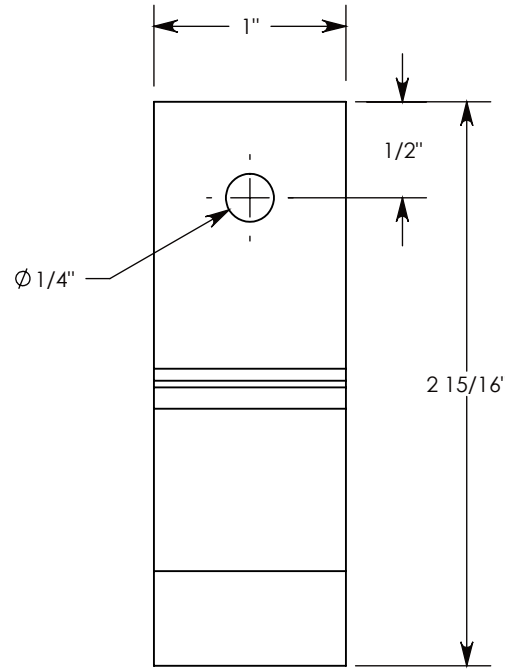
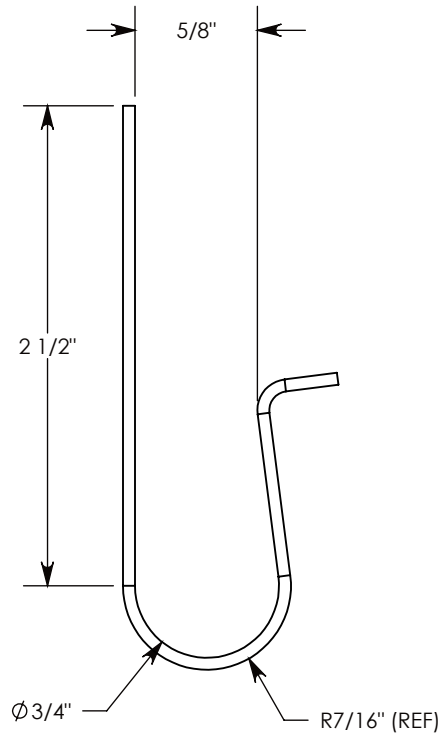

NOTE 1: .25" X 1.25" LONG CONCRETE SCREW INCLUDED (NOT SHOWN)
NOTE 2: REQUIRES ONSITE DRILLING FOR INSTALLATION

DRAWN BY: ROBIN FLINT

DATE: 1/28/2017

REVISION LEVEL: A

WEIGHT:

0.1 LBS.

MATERIAL:

STAINLESS STEEL



DESCRIPTION:

TRAFFIC CHANNEL SS CABLE CLIP

DIMENSIONS ARE IN INCHES
 TOLERANCES:
 FRACTIONAL: ± 1/8"
 ANGULAR: ± 2°

CONTACT INFORMATION:
 EMAIL: INFO@CONCASTINC.COM
 PHONE: (507) 732-4095
 FAX: (507) 732-4094

SHEET 1 OF 2

PART NUMBER:

8002TAP-001