

REV. A - RAL - 4/30/2018 - UPDATED TRAFFIC RATING NOTE
 REV. B - SIC - 7/21/2020 - UPDATED WEIGHT RATING TO MAX H-40, WAS H-20; ADDED SOIL BEARING PRESSURES

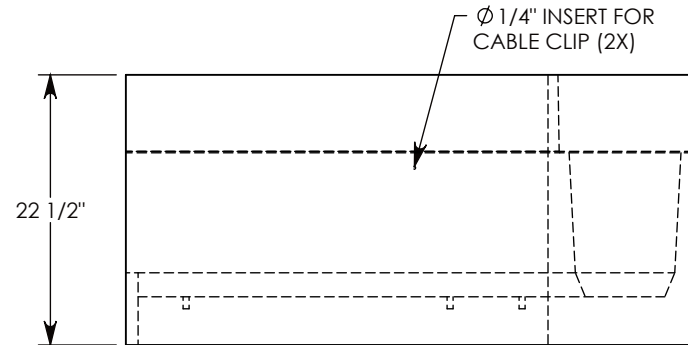
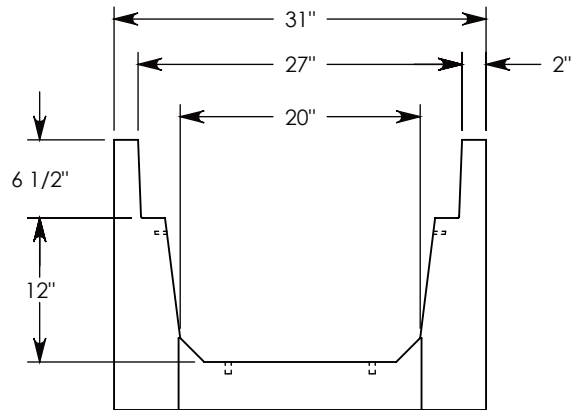
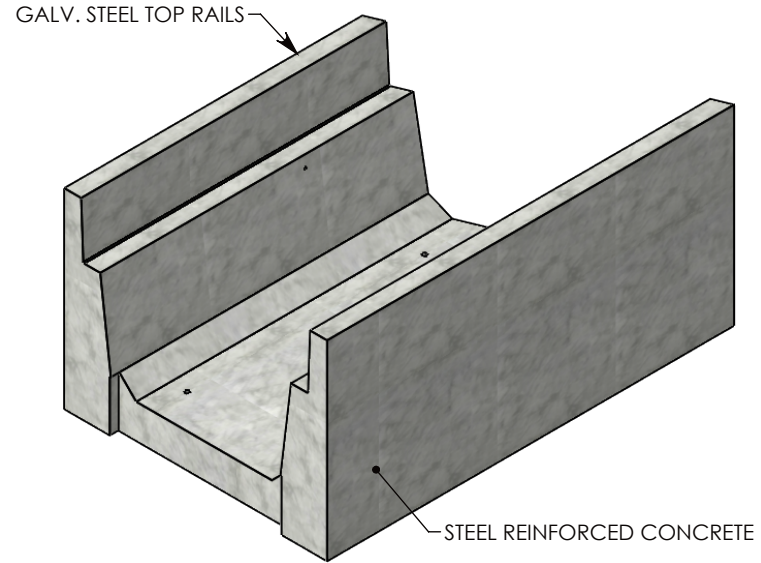
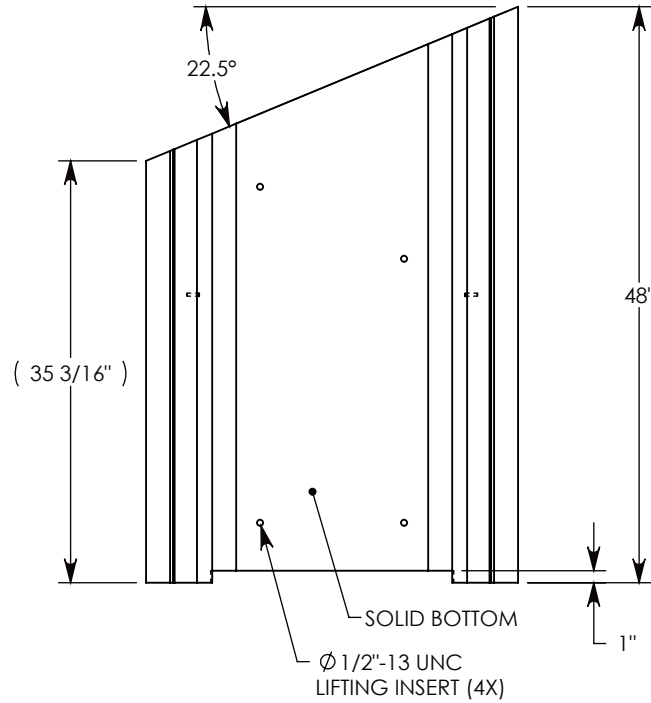

MAX AASHTO H-40 RATED - 64,000 LB. SINGLE AXLE LOAD
 DEPENDENT ON TRENCH COVER RATING
 MINIMUM ALLOWABLE SOIL BEARING PRESSURE - H-40: 3,500 PSF; H-20: 3,000 PSF

DRAWN BY: ROBIN FLINT	
CREATED DATE: 3/21/2011	REVISION LEVEL: B
SAVED DATE: 7/21/2020	SAVED BY: scallahan
WEIGHT: 930 LBS.	MATERIAL: CONCRETE

1010 NORTH STAR DRIVE
 P.O. BOX 69
 ZUMBROTA, MN 55992-0069

DESCRIPTION:		SHEET 1 OF 1
HT CHANNEL; 22.5 DEG. ANGLE		
DIMENSIONS ARE IN INCHES	CONTACT INFORMATION:	
TOLERANCES:	EMAIL: INFO@CONCASTINC.COM	
FRACTIONAL: ± 1/8"	PHONE: (507) 732-4095	
ANGULAR: ± 2°	FAX: (507) 732-4094	
PART NUMBER:		
8020HT 22.5L		