

COVER ASSEMBLES ONTO 24" INSIDE WIDTH  
HEAVY TRAFFIC H-20 RATED CONCAST CHANNEL.

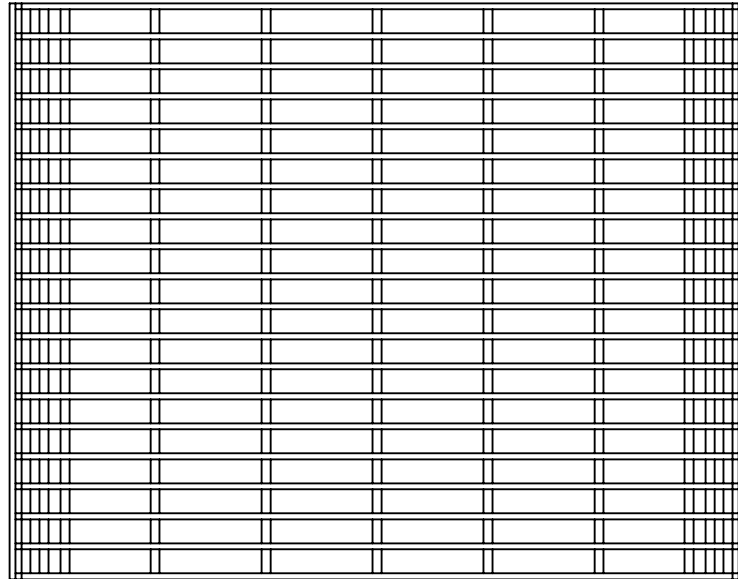

WELDED GALVANIZED STEEL GRATE

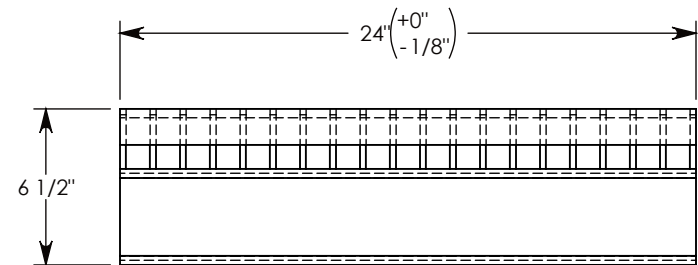
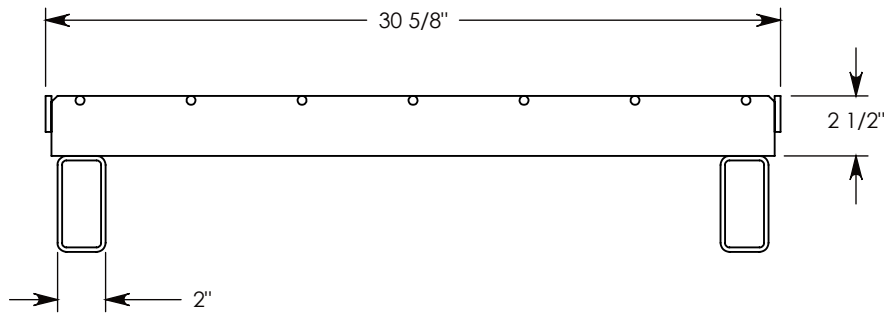
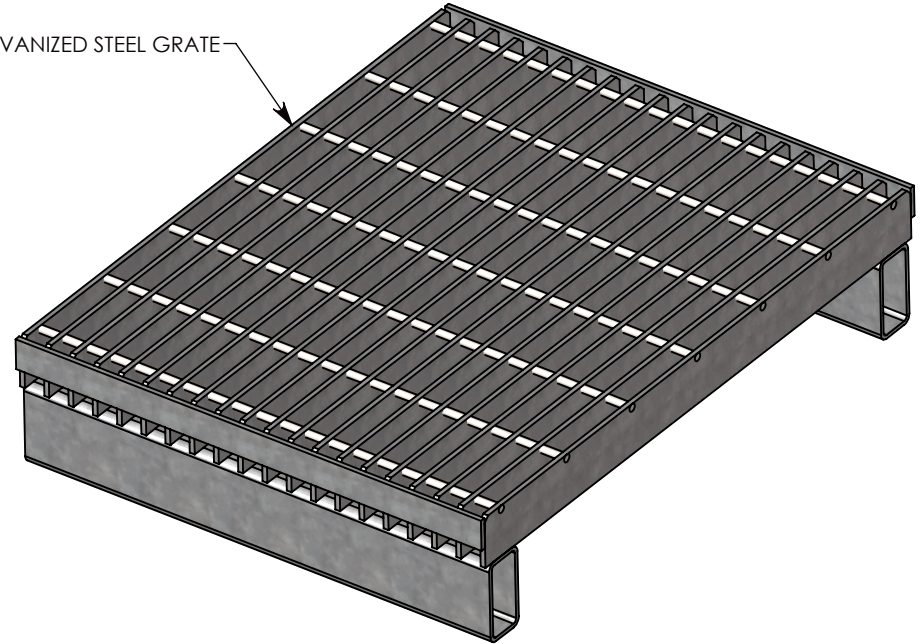

NOTE: FOR NON-STANDARD LENGTHS, THE PART NUMBER WILL CORRESPOND TO IT'S MEASURED LENGTH. IE: 8025HTV 18"

H-20 RATED - 32,000 LB. PER AXLE LOAD.

**DRAWN BY: ROBIN FLINT**

**DATE: 5/24/2015**

**REVISION LEVEL: 0**

**WEIGHT:**

**145 LBS.**

**MATERIAL:**

**GALVANIZED STEEL**



**DESCRIPTION:**

**VENTILATED STEEL COVER**

DIMENSIONS ARE IN INCHES  
TOLERANCES:  
FRACTIONAL:  $\pm 1/8"$   
ANGULAR:  $\pm 2^\circ$

CONTACT INFORMATION:  
EMAIL: INFO@CONCASTINC.COM  
PHONE: (507) 732-4095  
FAX: (507) 732-4094

SHEET 1 OF 1

**PART NUMBER:**

**8025HTV**