

REV A: (TCJ) 9/6/2017 - ADDED COVER SUPPORT RAILS  
 REV B: (TCJ) 2/8/2018 - UPDATED SUPPORT RAIL  
 REV. C - SIC - 7/19/2019 - UPDATED VIEWS, ANNOTATIONS, AND DIMENSIONS

3/8-16 UNC X 2.50" LG HEX HD BOLT, GRADE 8, GRADE 8  
 P/N: HHB.38-2.5G8 QTY: 2

3/8" STD WASHER - 1" OD  
 P/N: WSR.38-1 QTY: 2

Ø 1/2"-13 UNC  
 LIFTING INSERT (4X)

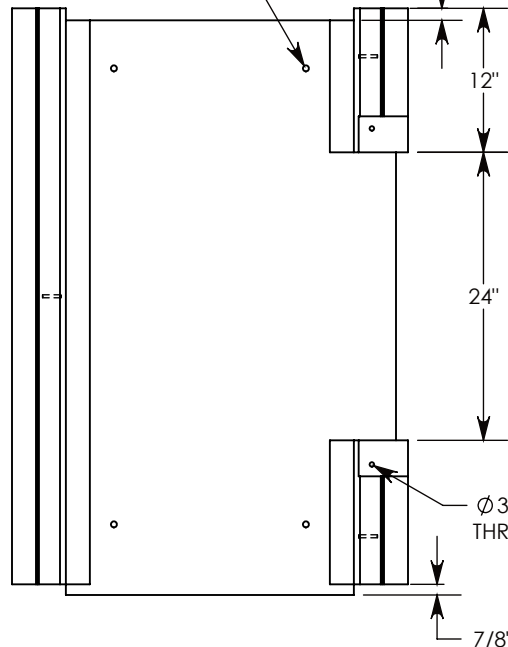

GALV. STEEL TOP RAIL

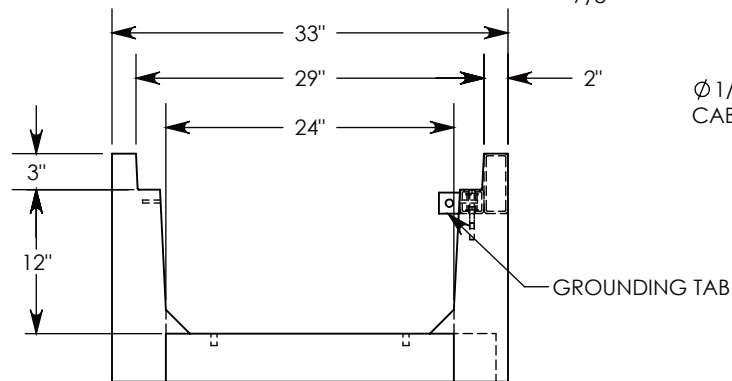
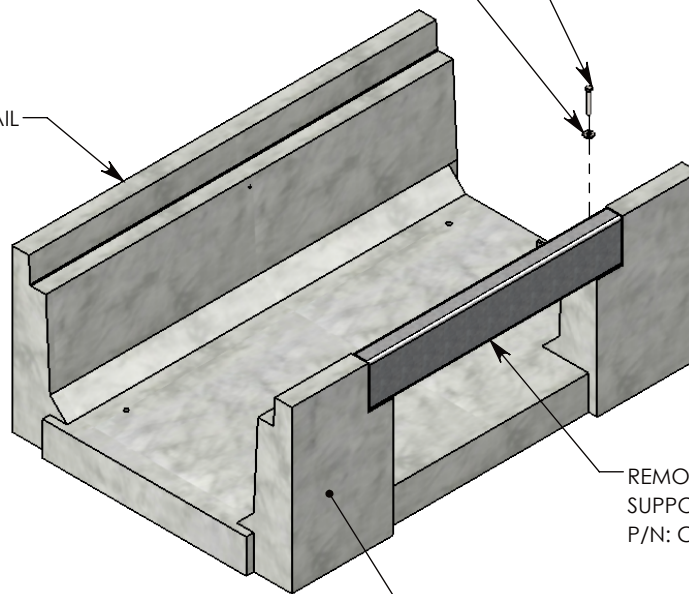

Ø 1/4" INSERT FOR  
 CABLE CLIPS (3X)

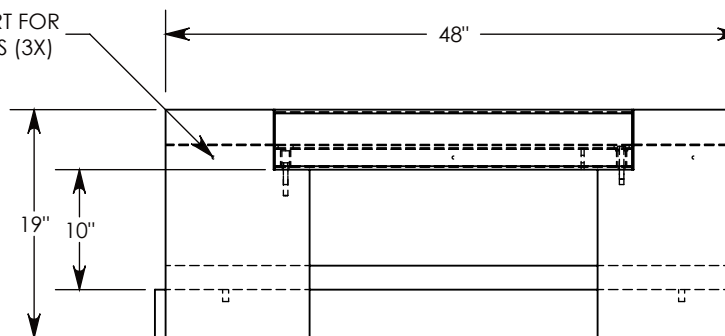

AASHTO H-20 RATED - 32,000 LB. SINGLE AXLE LOAD

<b>DRAWN BY:</b> ROBIN LEWIS	
<b>CREATED DATE:</b> 7/14/2008	<b>REVISION LEVEL:</b> C
<b>SAVED DATE:</b> 1/28/2020	<b>SAVED BY:</b> scallahan
<b>WEIGHT:</b> 886 LBS.	<b>MATERIAL:</b> NOTED

1010 NORTH STAR DRIVE  
 P.O. BOX 69  
 ZUMBROTA, MN 55992-0069

**DESCRIPTION:**  
**HEAVY TRAFFIC UNIVERSAL CHANNEL**

DIMENSIONS ARE IN INCHES  
 TOLERANCES:  
 FRACTIONAL: ± 1/8"  
 ANGULAR: ± 2°

CONTACT INFORMATION:  
 EMAIL: INFO@CONCASTINC.COM  
 PHONE: (507) 732-4095  
 FAX: (507) 732-4094

SHEET 1 OF 1

**PART NUMBER:**  
**8026HT3 (24X0)**