

REV A-07/18/2017-RAL- CHANGED LENGTH FROM 24" TO 32"

FIBERCRETE[®]
TRENCH
SYSTEM

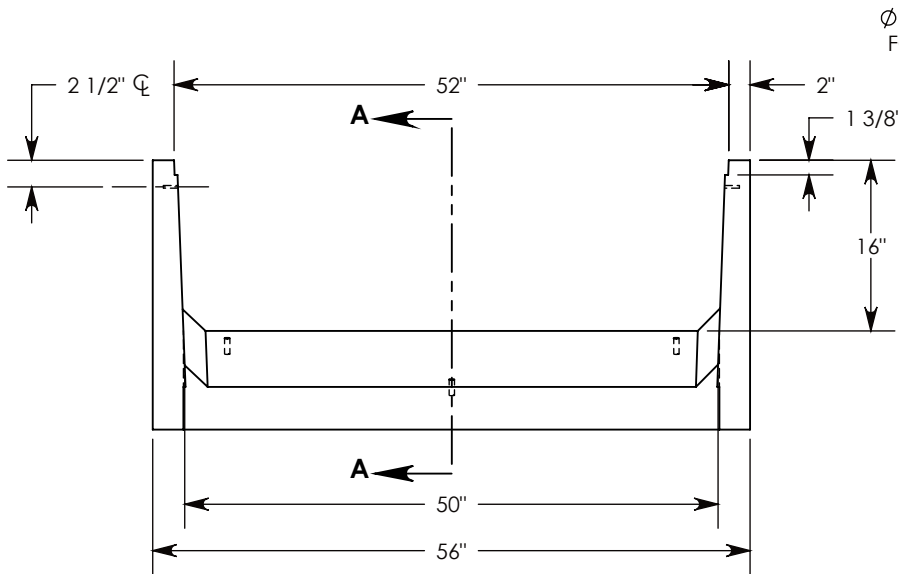

Ø 1/4"-13 UNC INSERTS
FOR CABLE CLPS (2X)

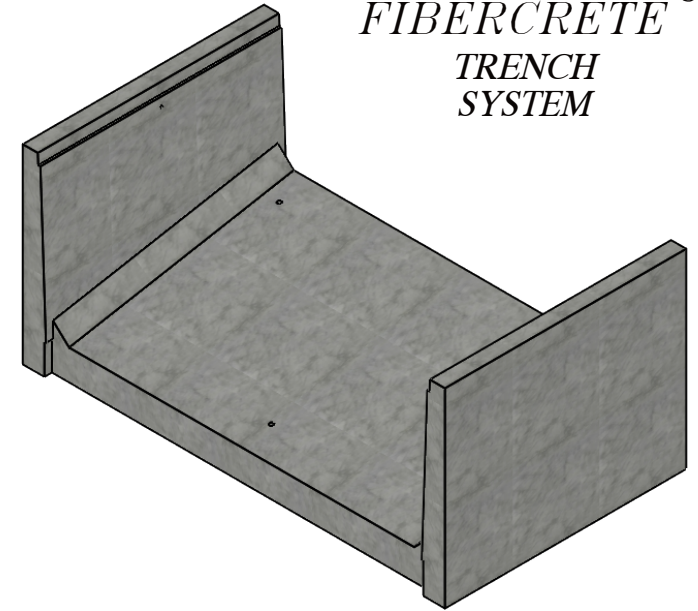
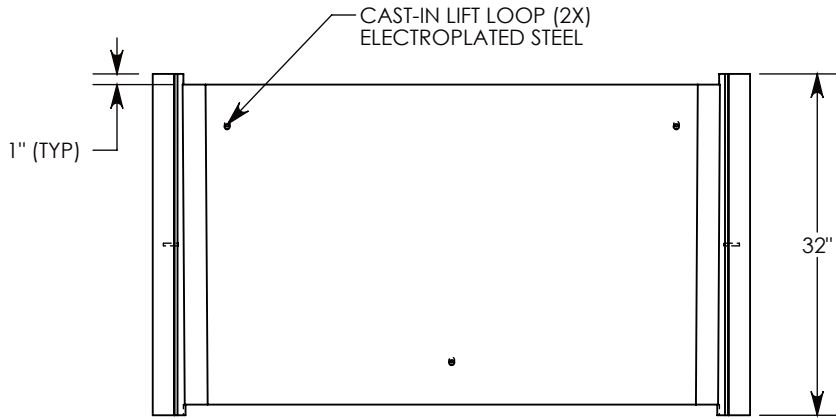
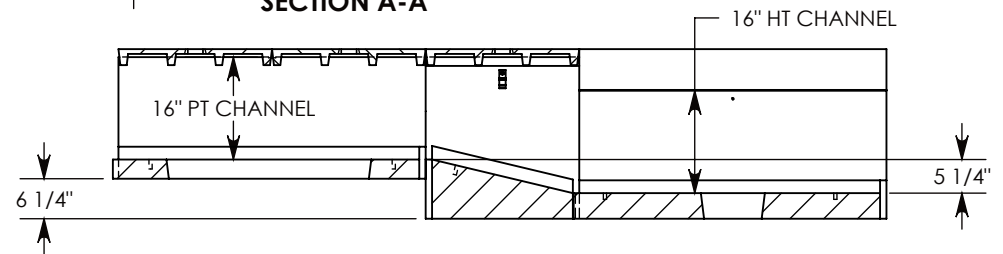
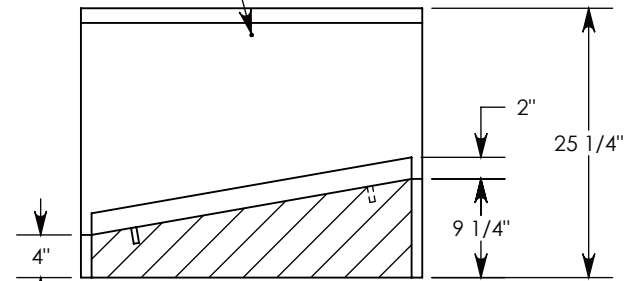

NOTE 1: PEDESTRIAN RATED - 200 LB. PER SQ. FOOT

DRAWN BY: ROBIN FLINT

DATE: 7/19/2017

REVISION LEVEL: A

WEIGHT:

1183 LBS.

MATERIAL:

CONCRETE

CONCAST
 1010 NORTH STAR DRIVE
 P.O. BOX 69
 ZUMBROTA, MN 55992-0069

DESCRIPTION:

PT TRANSITION CHANNEL TO HT

DIMENSIONS ARE IN INCHES
 TOLERANCES:
 FRACTIONAL: ± 1/8"
 ANGULAR: ± 2°

CONTACT INFORMATION:
 EMAIL: INFO@CONCASTINC.COM
 PHONE: (507) 732-4095
 FAX: (507) 732-4094

SHEET 1 OF 1

PART NUMBER:

805016PTR1