

REV A-07/18/2017-RAL- CHANGED LENGTH FROM 24" TO 32"

FIBERCRETE®
TRENCH SYSTEM

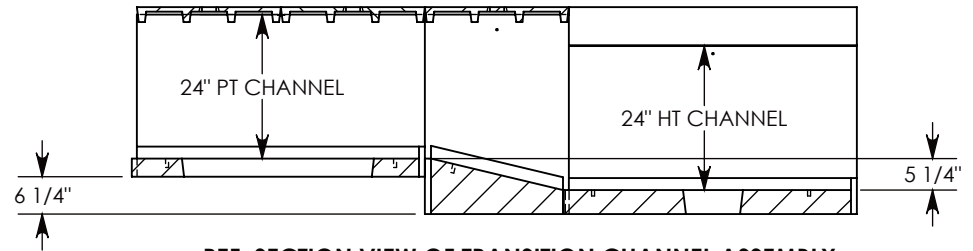
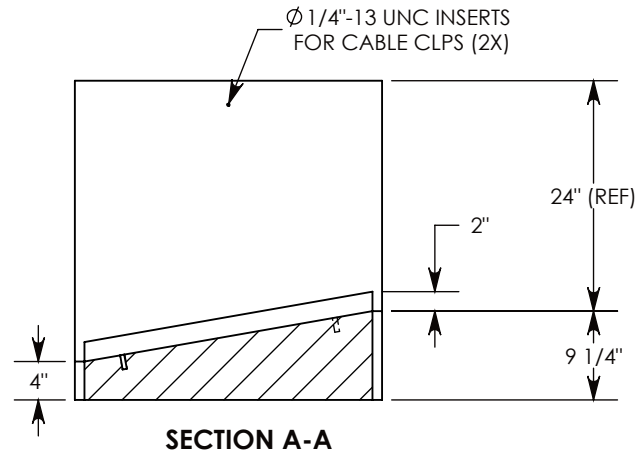
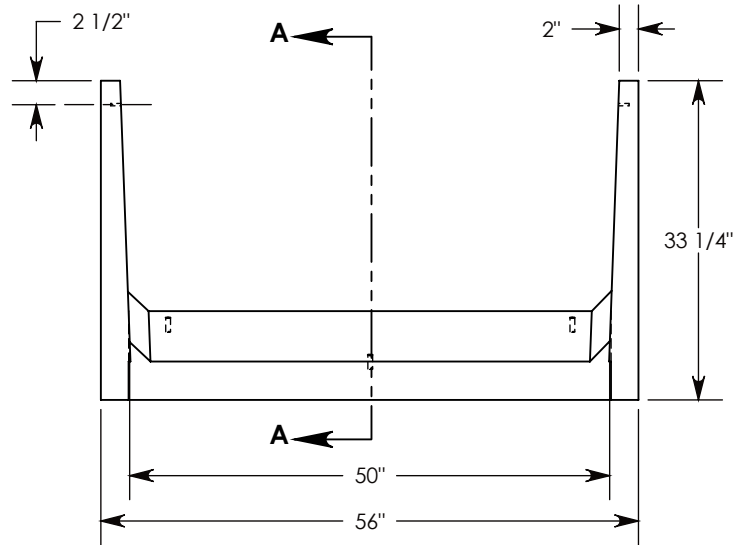
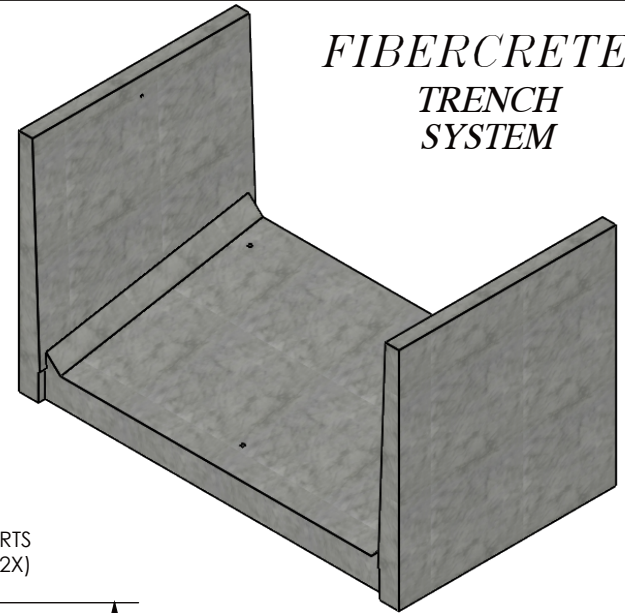
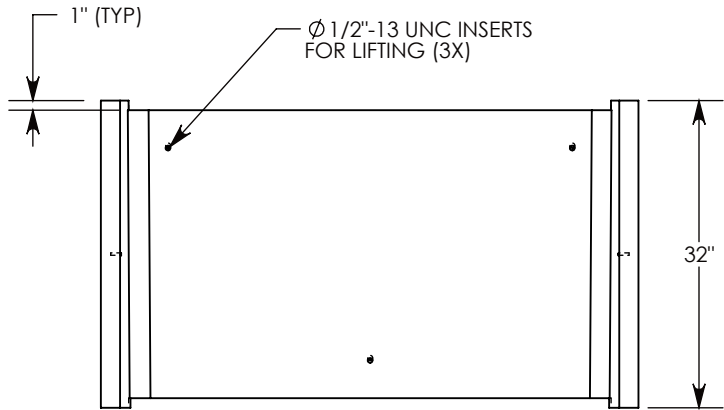

NOTE 1: PEDESTRIAN RATED - 200 LB. PER SQ. FOOT

REF. SECTION VIEW OF TRANSITION CHANNEL ASSEMBLY

DRAWN BY: ROBIN FLINT

DATE: 7/18/2017

REVISION LEVEL: A

WEIGHT:

1276 LBS.

MATERIAL:

CONCRETE

CONCAST
 1010 NORTH STAR DRIVE
 P.O. BOX 69
 ZUMBROTA, MN 55992-0069

DESCRIPTION:

PT TRANSITION CHANNEL TO HT

DIMENSIONS ARE IN INCHES
 TOLERANCES:
 FRACTIONAL: \pm 1/8"
 ANGULAR: \pm 2°

CONTACT INFORMATION:
 EMAIL: INFO@CONCASTINC.COM
 PHONE: (507) 732-4095
 FAX: (507) 732-4094

SHEET 1 OF 1

PART NUMBER:

805024PTR1