

REV A-07/18/2017-RAL- CHANGED LENGTH FROM 24" TO 32"

**FIBERCRETE<sup>®</sup>**  
**TRENCH**  
**SYSTEM**

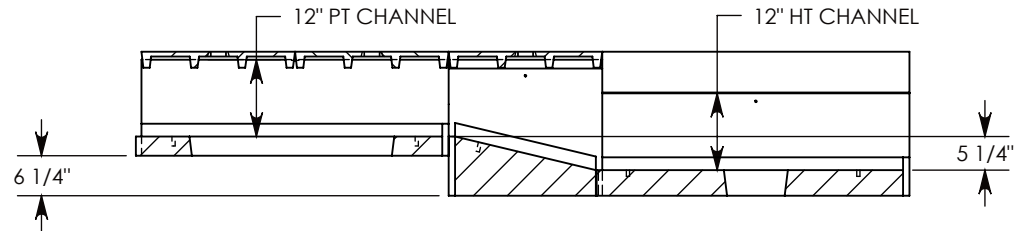
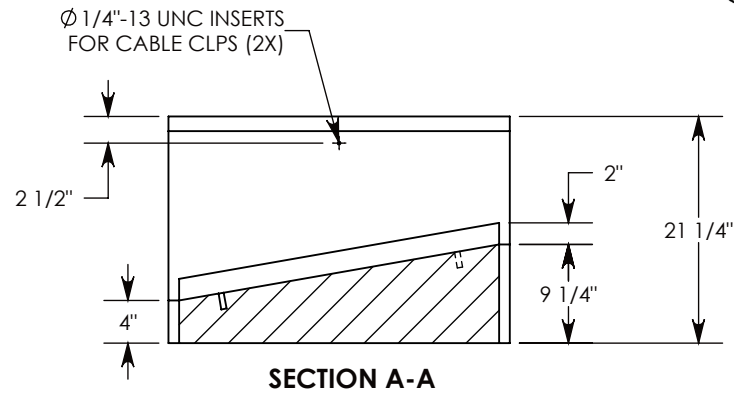
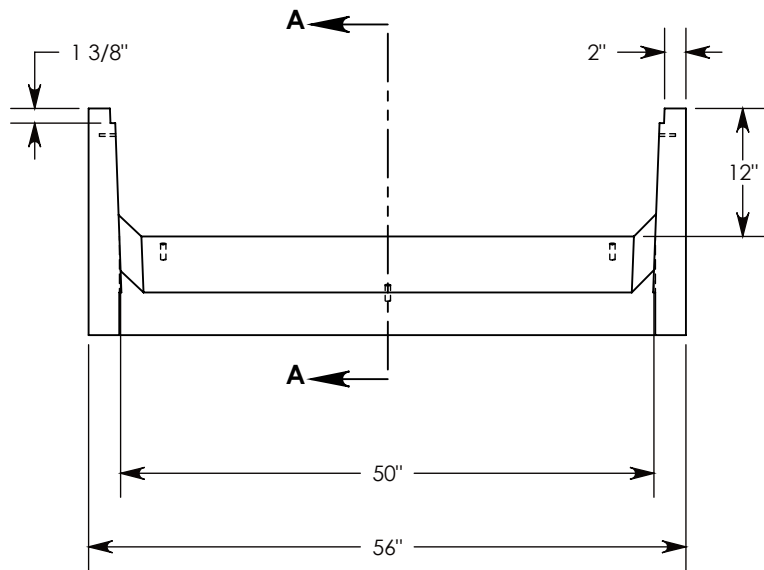
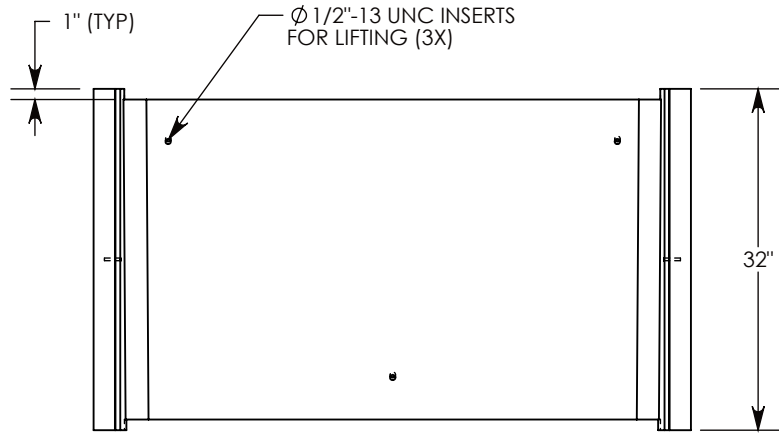
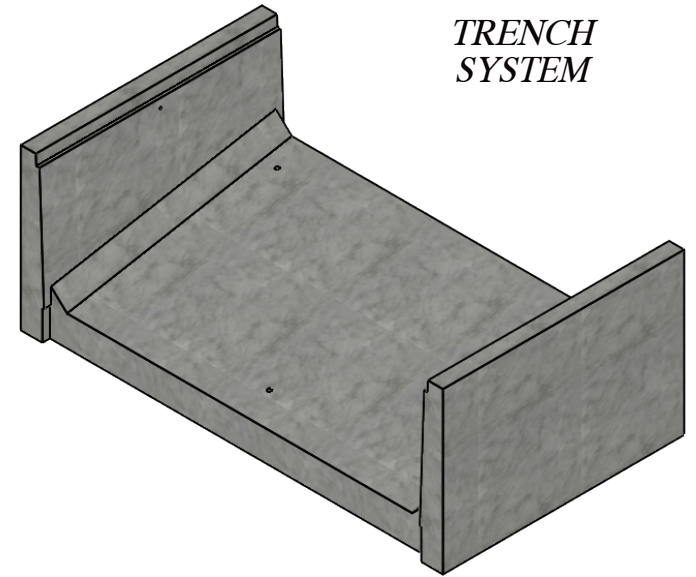

**NOTE 1:** PEDESTRIAN RATED - 200 LB. PER SQ. FOOT

**DRAWN BY:** ROBIN FLINT

**DATE:** 7/19/2017

**REVISION LEVEL:** A

**WEIGHT:**

1133 LBS.

**MATERIAL:**

CONCRETE



**DESCRIPTION:**

**PT TRANSITION CHANNEL TO HT**

DIMENSIONS ARE IN INCHES  
 TOLERANCES:  
 FRACTIONAL: ± 1/8"  
 ANGULAR: ± 2°

CONTACT INFORMATION:  
 EMAIL: INFO@CONCASTINC.COM  
 PHONE: (507) 732-4095  
 FAX: (507) 732-4094

SHEET 1 OF 1

**PART NUMBER:**

8050PTRT1