

- 1/2-13 UNC X 1" LG HEX HD BOLT
P/N: HHB.5-1 (2X)
- 4" HOLD-DOWN CLAMP
P/N: HDC-1 (2X)
- 1/2-13 UNC SPRING NUT
P/N: USN-.5 (2X)
- 4" LONG X 7/8" DEEP UNISTRUT
P/N: UNST4 (2X)

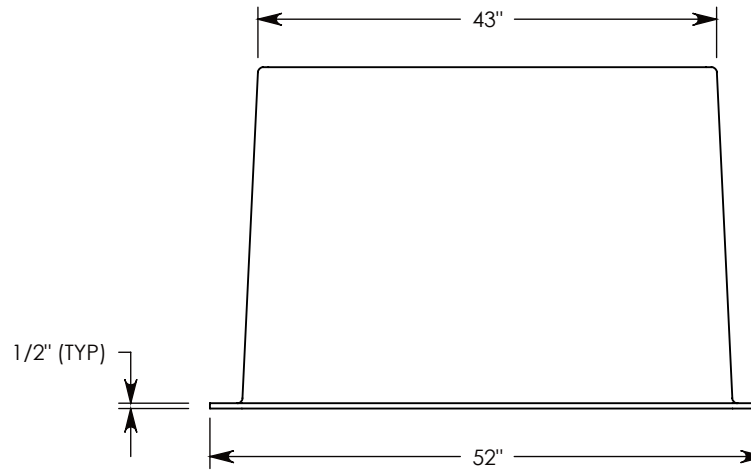
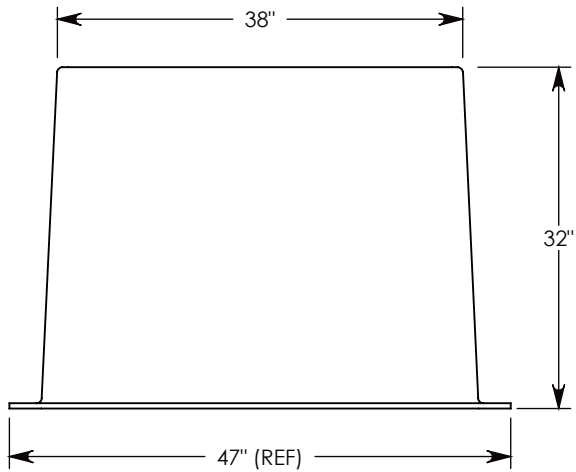
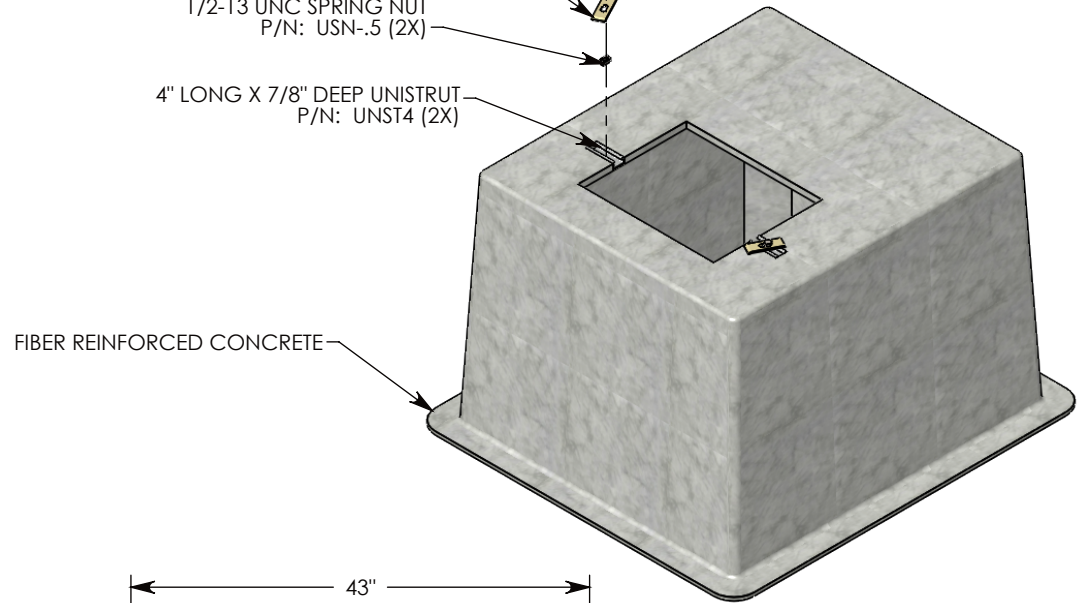

DRAWN BY: COLIN HORTOP

DATE: 5/29/2016

REVISION LEVEL: 0

WEIGHT:

362 LBS.

MATERIAL:

FIBERCRETE



1010 NORTH STAR DRIVE
P.O. BOX 69
ZUMBROTA, MN 55992-0069

DESCRIPTION:

FIBERCRETE BOX PAD

DIMENSIONS ARE IN INCHES
TOLERANCES:
FRACTIONAL: ± 1/8"
ANGULAR: ± 2°

CONTACT INFORMATION:
EMAIL: INFO@CONCASTINC.COM
PHONE: (507) 732-4095
FAX: (507) 732-4094

SHEET 1 OF 1

PART NUMBER:

FC-38-43-32-2016 (6)