

- 1/2-13 UNC X 1" LG HEX HD BOLT  
P/N: HHB.5-1 (2X)
- 1/2-13 UNC SPRING NUT  
P/N: USN-.5 (2X)
- 4" LONG X 7/8" DEEP UNISTRUT  
P/N: UNST4 (2X)
- 4" HOLD-DOWN CLAMP  
P/N: HDC-1 (2X)

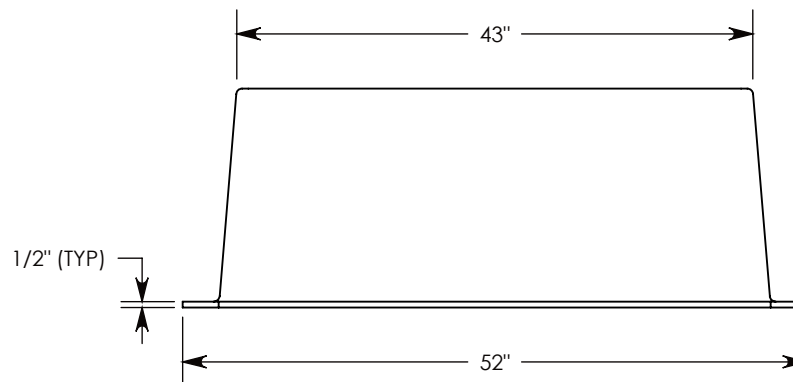
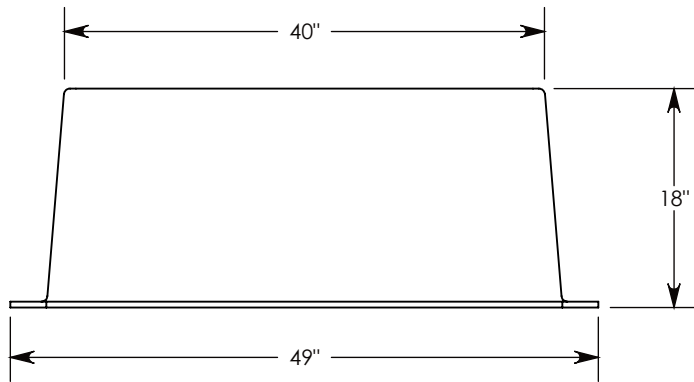
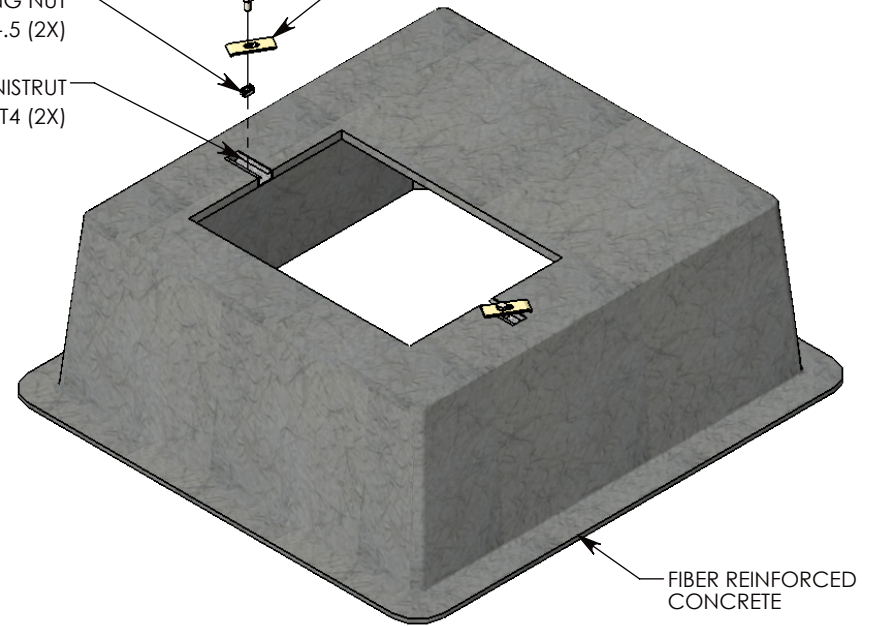

**DRAWN BY: JESSE GUTTING**

**DATE: 10/9/2017**

**REVISION LEVEL: 0**

**WEIGHT:**

**197 LBS.**

**MATERIAL:**

**FIBERCRETE FC**



1010 NORTH STAR DRIVE  
P.O. BOX 69  
ZUMBROTA, MN 55992-0069

**DESCRIPTION:**

**FIBERCRETE BOX PAD W/HARDWARE**

DIMENSIONS ARE IN INCHES  
TOLERANCES:  
FRACTIONAL: ± 1/8"  
ANGULAR: ± 2°

CONTACT INFORMATION:  
EMAIL: INFO@CONCASTINC.COM  
PHONE: (507) 732-4095  
FAX: (507) 732-4094

SHEET 1 OF 1

**PART NUMBER:**

**FC-40-43-18-2618(6)**