

**FIBERCRETE**®

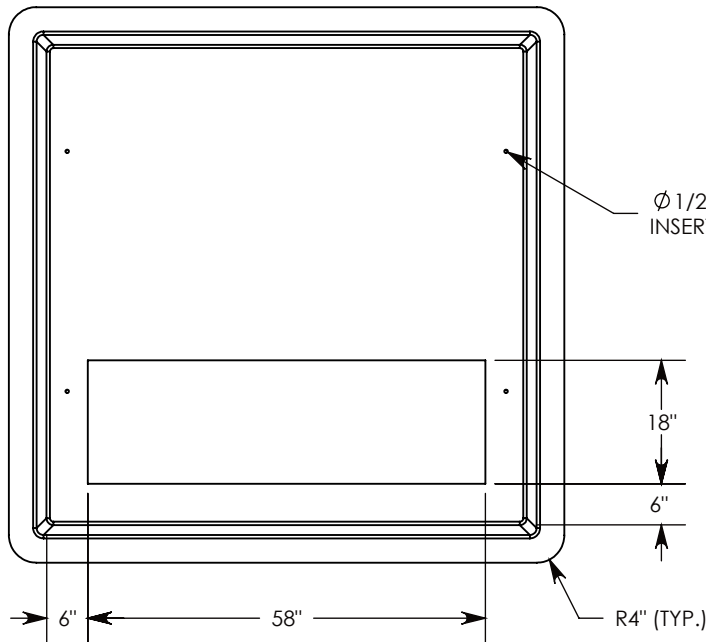

FIBER REINFORCED CONCRETE

EXCLUDING THE FINIS, THE REAR TRANSFORMER SUPPORT MUST BE WITHIN 6" OF THIS EDGE.

Ø 1/2"-13 UNC THREADED INSERT FOR LIFTING (4X)

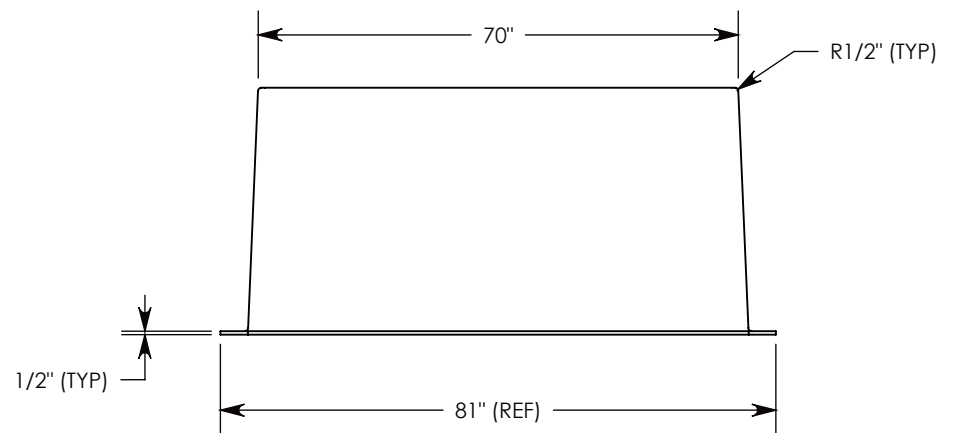
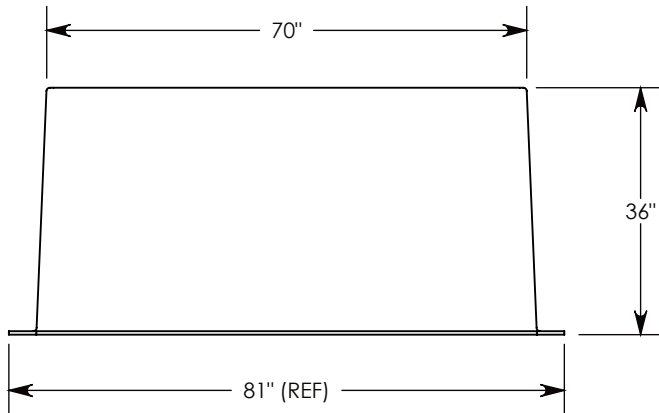
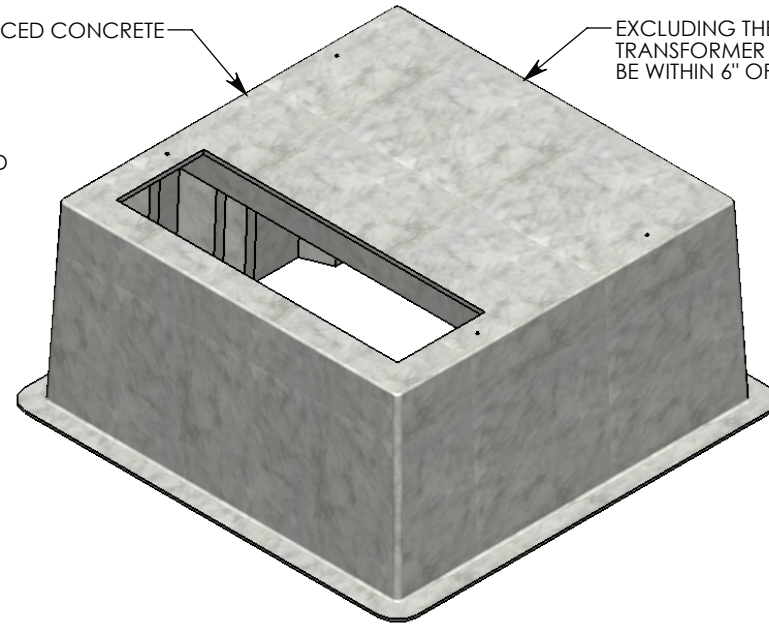

**NOTE 1:** IF SPECIFIC INSERTS OR MOUNTING HARDWARE ARE REQUIRED, PLEASE SPECIFY WHEN ORDERING.

<b>DRAWN BY: ROBIN FLINT</b>	
<b>DATE: 4/20/2016</b>	<b>REVISION LEVEL: A</b>
<b>WEIGHT: 1292 LBS.</b>	<b>MATERIAL: FIBERCRETE FC</b>



1010 NORTH STAR DRIVE  
P.O. BOX 69  
ZUMBROTA, MN 55992-0069

<b>DESCRIPTION:</b>		
<b>FIBERCRETE PAD BOX</b>		
DIMENSIONS ARE IN INCHES TOLERANCES: FRACTIONAL: ± 1/8" ANGULAR: ± 2°	CONTACT INFORMATION: EMAIL: INFO@CONCASTINC.COM PHONE: (507) 732-4095 FAX: (507) 732-4094	SHEET 1 OF 1
<b>PART NUMBER:</b>		
<b>FC-70-70-36-1858 (6)</b>		