

ITEM NO.	PART NUMBER	DESCRIPTION	QTY.
1	C-CLAMP	CLAMP WITH $\varnothing 3/8$ -16 UNC X 2" BOLT	12

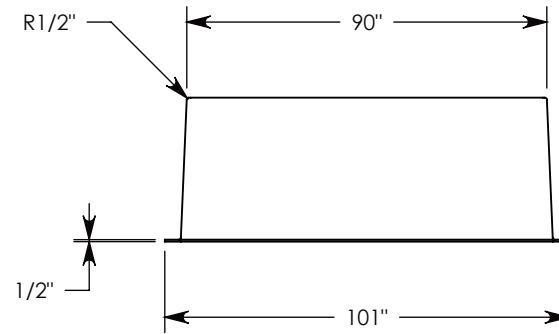
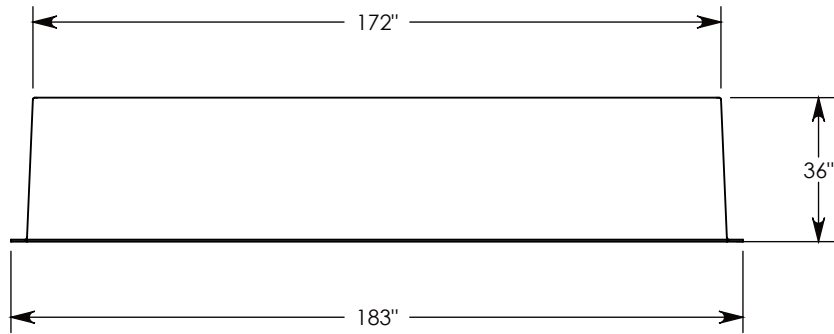
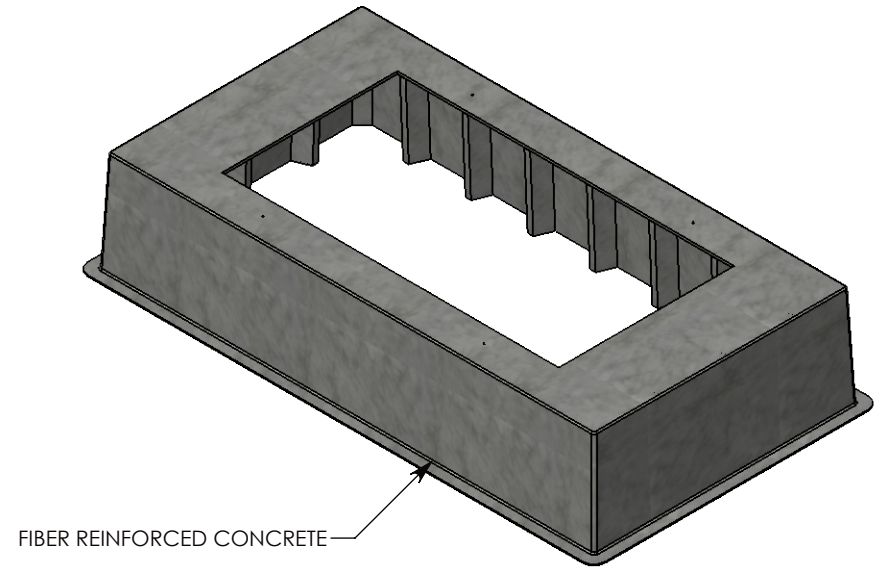
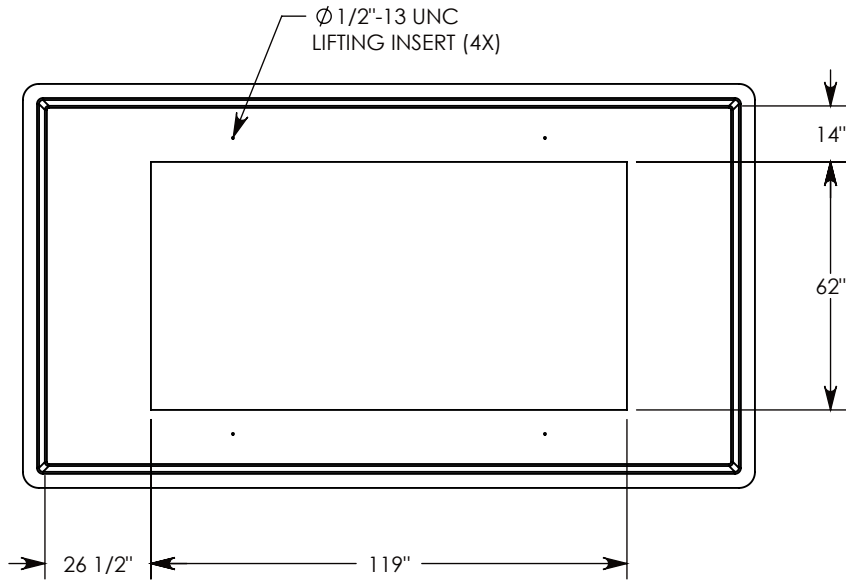

**NOTE 1:** IF SPECIFIC INSERTS OR MOUNTING HARDWARE ARE REQUIRED, PLEASE SPECIFY WHEN ORDERING.

DRAWN BY: **JESSE GUTTING**

CREATED DATE: **9/28/2020** REVISION LEVEL: **0**

SAVED DATE: **9/28/2020** SAVED BY: **jgutting**

WEIGHT: **1752 LBS.** MATERIAL: **FIBERCRETE FC**

**CONCAST**  
 1010 NORTH STAR DRIVE  
 P.O. BOX 69  
 ZUMBROTA, MN 55992-0069

DESCRIPTION:

**FIBERCRETE PAD BOX**

DIMENSIONS ARE IN INCHES  
 TOLERANCES:  
 FRACTIONAL:  $\pm 1/8"$   
 ANGULAR:  $\pm 2^\circ$

CONTACT INFORMATION:  
 EMAIL: [INFO@CONCASTINC.COM](mailto:INFO@CONCASTINC.COM)  
 PHONE: (507) 732-4095  
 FAX: (507) 732-4094

SHEET 1 OF 1

PART NUMBER:

**FC-90-172-36-PMX**