

FIBERCRETE®

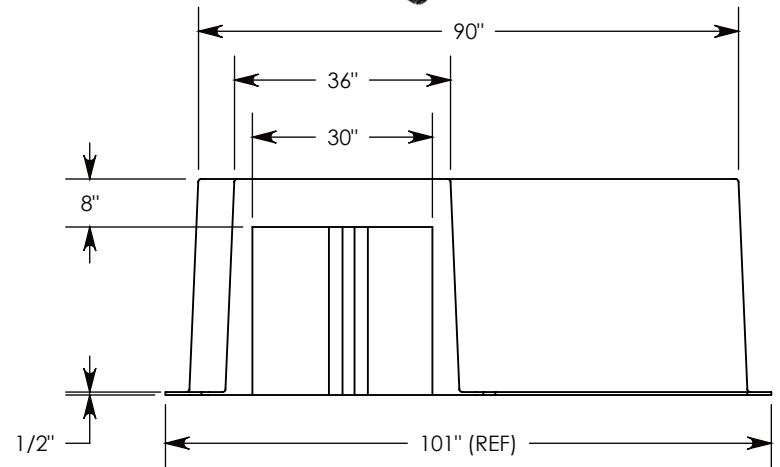
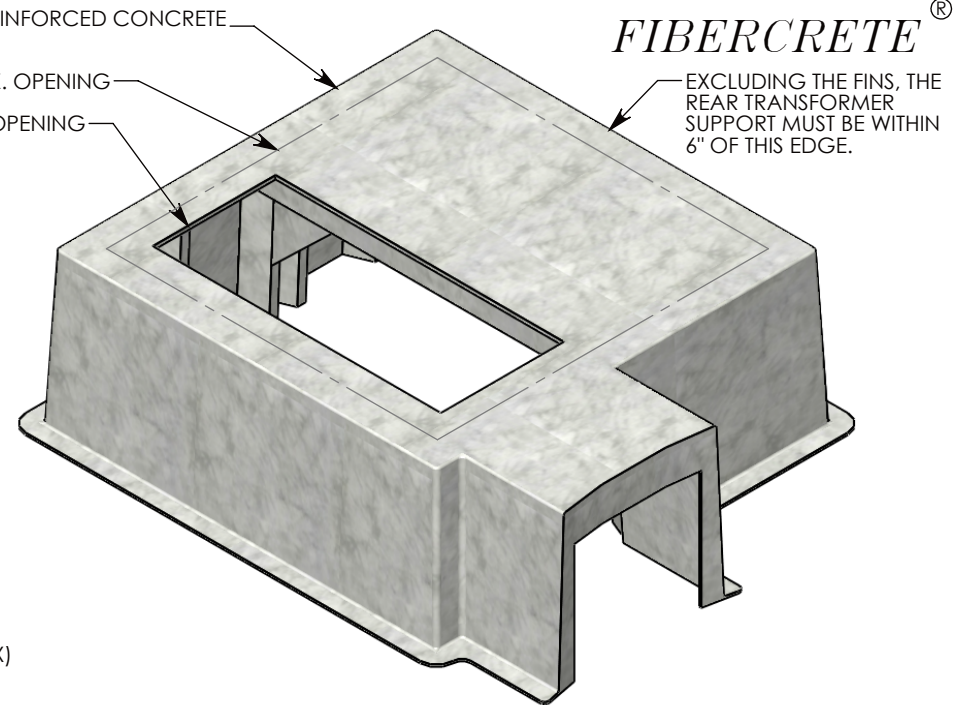
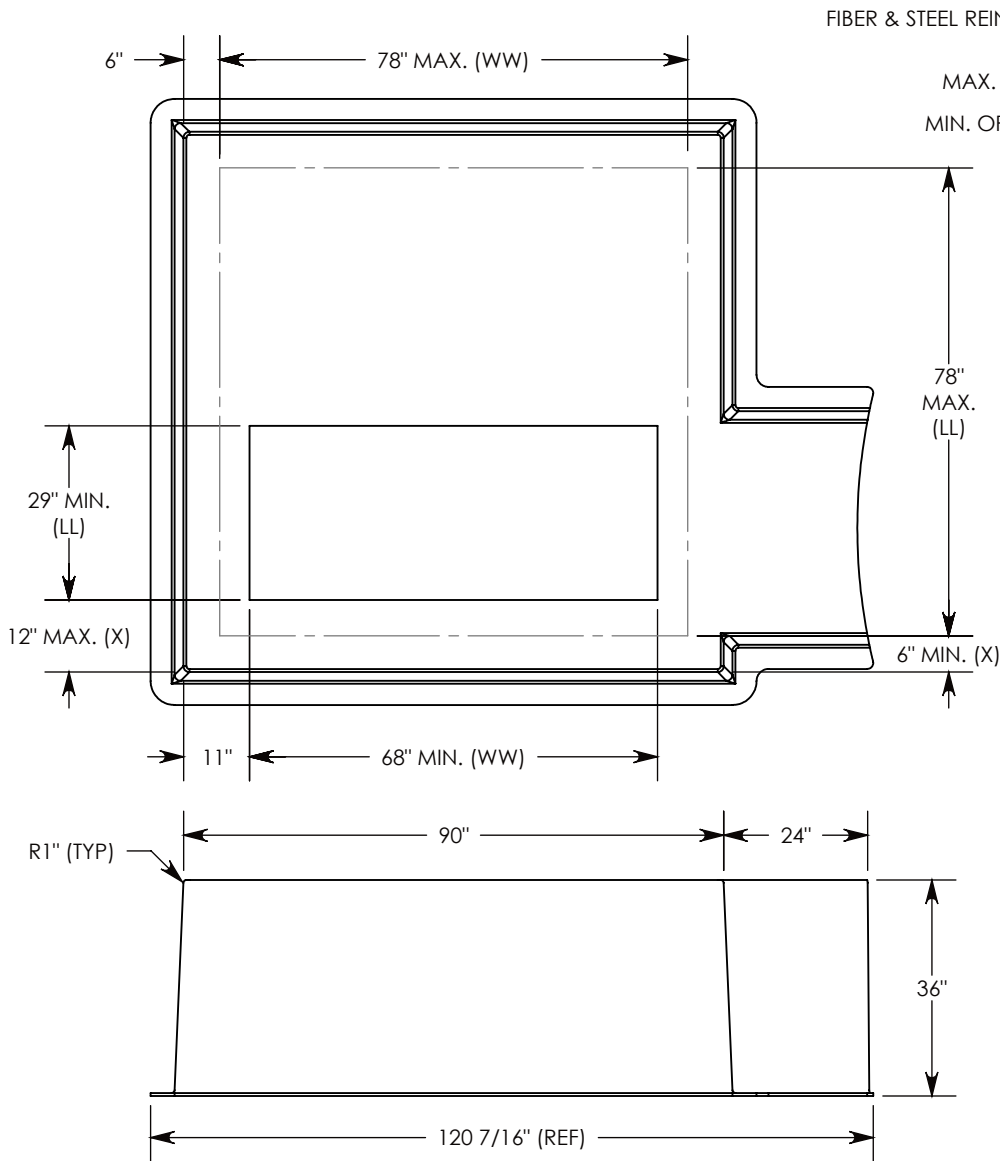

Ø 1/2"-13 UNC LIFTING INSERTS WILL BE CAST INTO BOX PAD
 IF SPECIFIC INSERTS OR MOUNTING HARDWARE ARE REQUIRED, PLEASE SPECIFY WHEN ORDERING.
 PART NUMBER IS BASED ON OPENING SIZE. IE: THE SMALLEST OPENING PAD IS P/N: FC-90-90-36-IT-2968 (12)
 THE LARGEST OPENING PAD IS P/N: FC-90-90-36-IT-7878

DRAWN BY: ROBIN FLINT	
DATE: 6/27/2013	REVISION LEVEL: 0
WEIGHT:	MATERIAL:
- LBS.	FIBERCRETE FC

CONCAST
 1010 NORTH STAR DRIVE
 P.O. BOX 69
 ZUMBROTA, MN 55992-0069

DESCRIPTION:		
FIBERCRETE BOX PAD		
DIMENSIONS ARE IN INCHES	CONTACT INFORMATION:	
TOLERANCES:	EMAIL: INFO@CONCASTINC.COM	SHEET 1 OF 1
FRACTIONAL: ± 1/8"	PHONE: (507) 732-4095	
ANGULAR: ± 2°	FAX: (507) 732-4094	
PART NUMBER:		
FC-90-90-36-IT-LLWW (X)		