

**DETAIL A
SCALE 1 : 11**

STEEL REINFORCED CONCRETE BASE
W/CAST-IN GALV. STEEL FRAME
P/N: FHR-30-48-24-R

CON-DUCT TERMINATIONS ARE CAST INTO BOX
SIDEWALLS. THEY FIT UP TO 4" PVC PIPE. TO
ACCESS THE HOLES, BREAK PLASTIC SEAL. SEE NOTE 2.

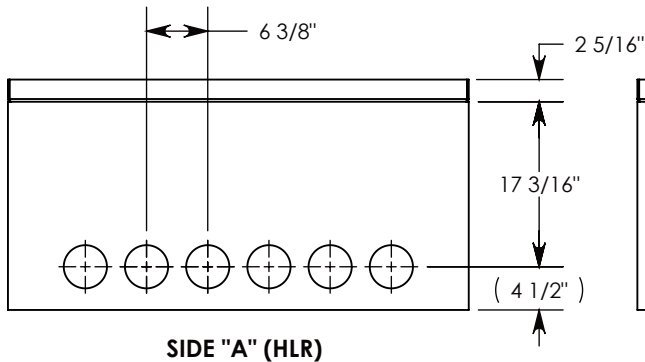
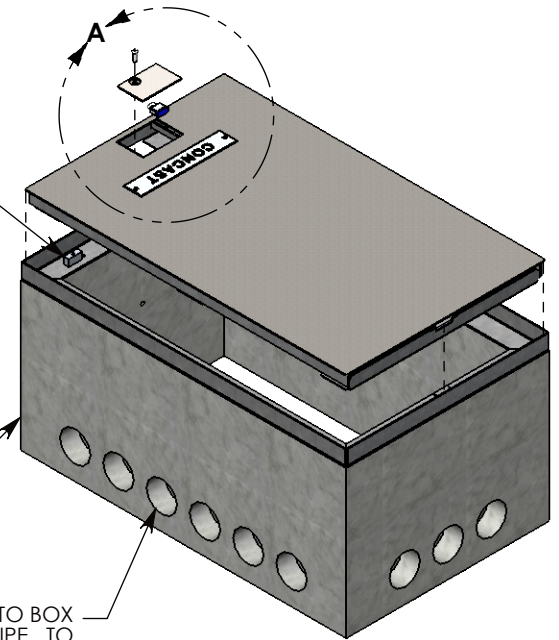

SIDE "A" (HLR)

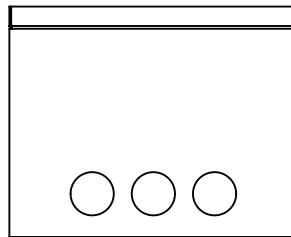

SIDE "B" (HLR)

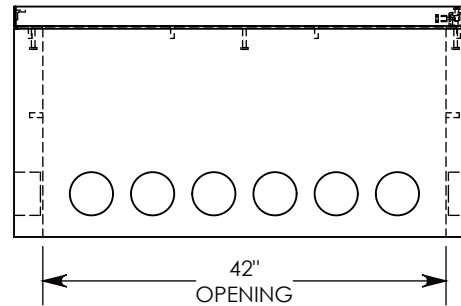

SIDE "C"

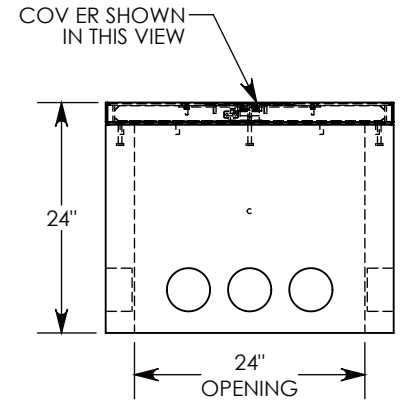

SIDE "D"

NOTE 1: CUSTOM KEYPED FOR LOCKING THE ACCESS COVER. SURELOCK BOLT CAN ONLY BE REMOVED BY USING THE CONCAST SUPPLIED TOOL P/N: 8000SL

NOTE 2: FOR PVC SIZES SMALLER THAN 4", USE CONCAST RC41 (REDUCING COUPLER)

NOTE 3: TO REPLACE SURELOCK BOLT WITH PENTA HEAD BOLT (P/N: PTA.38-1.5) ORDER UNDER PART NUMBER FHRPP-30-48-24

AASHTO H-20 RATED – 32,000 LB. SINGLE AXLE LOAD

DRAWN BY: JESSE GUTTING	
CREATED DATE: 3/29/2010	REVISION LEVEL: 0
SAVED DATE: 10/24/2019	SAVED BY: JGUTTING
WEIGHT: 878 LBS.	MATERIAL: NOTED

1010 NORTH STAR DRIVE
P.O. BOX 69
ZUMBROTA, MN 55992-0069

DESCRIPTION:		SHEET 1 OF 1
HEAVY TRAFFIC HANDHOLE		
DIMENSIONS ARE IN INCHES TOLERANCES: FRACTIONAL: ± 1/8" ANGULAR: ± 2°	CONTACT INFORMATION: EMAIL: INFO@CONCASTINC.COM PHONE: (507) 732-4095 FAX: (507) 732-4094	
PART NUMBER:		
FHRSLP-30-48-24		