

REV. A - RAL - 1/12/2018 - UPDATED THE COVER SUPPORT RAIL

REV. B - SIC - 7/25/2019 - UPDATED VIEWS AND DIMENSIONS; ADDED 1/4" CABLE CLIP INSERTS

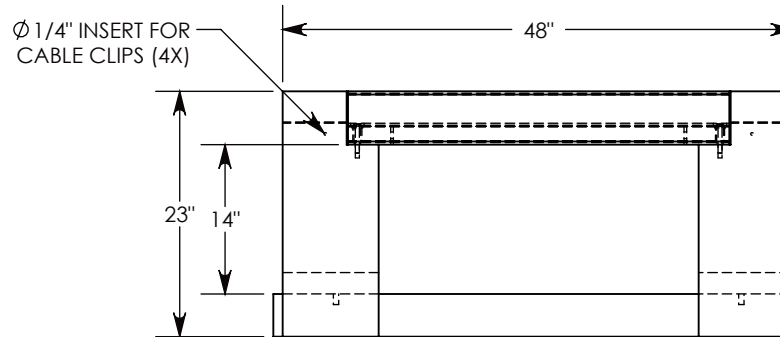
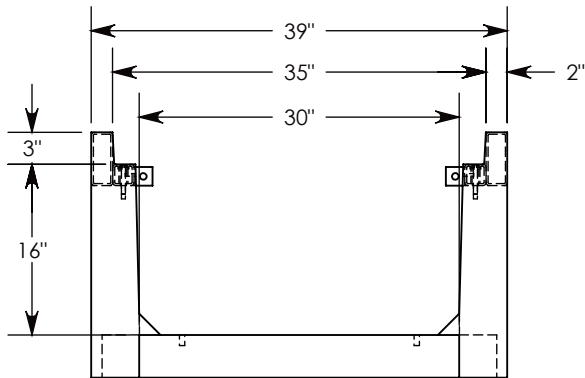
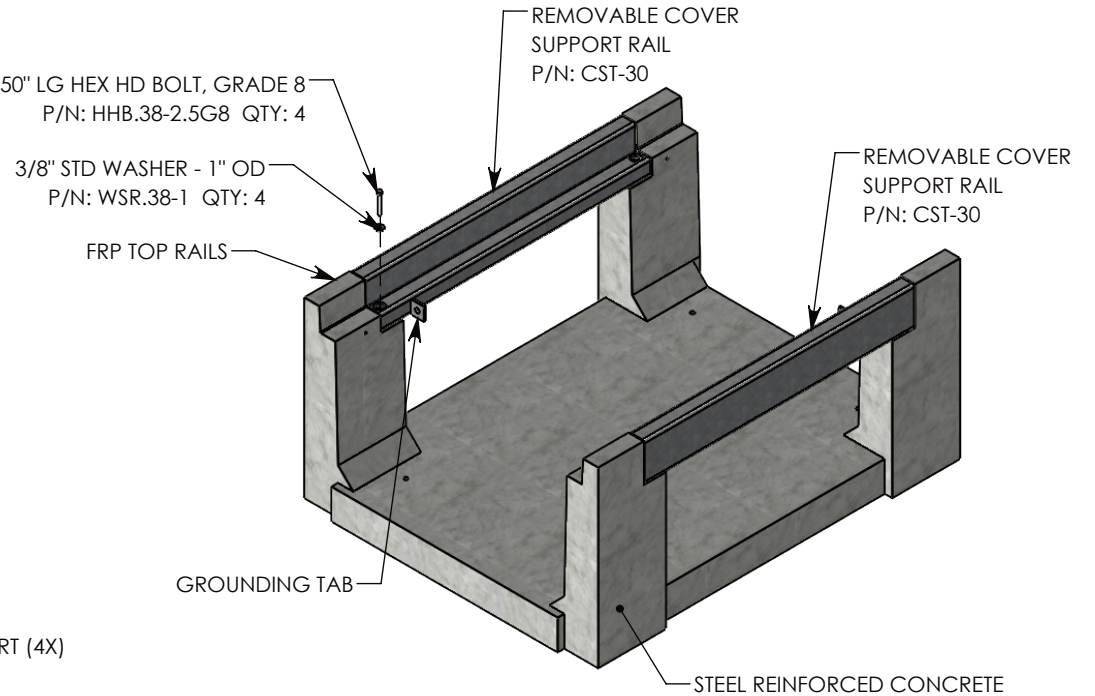
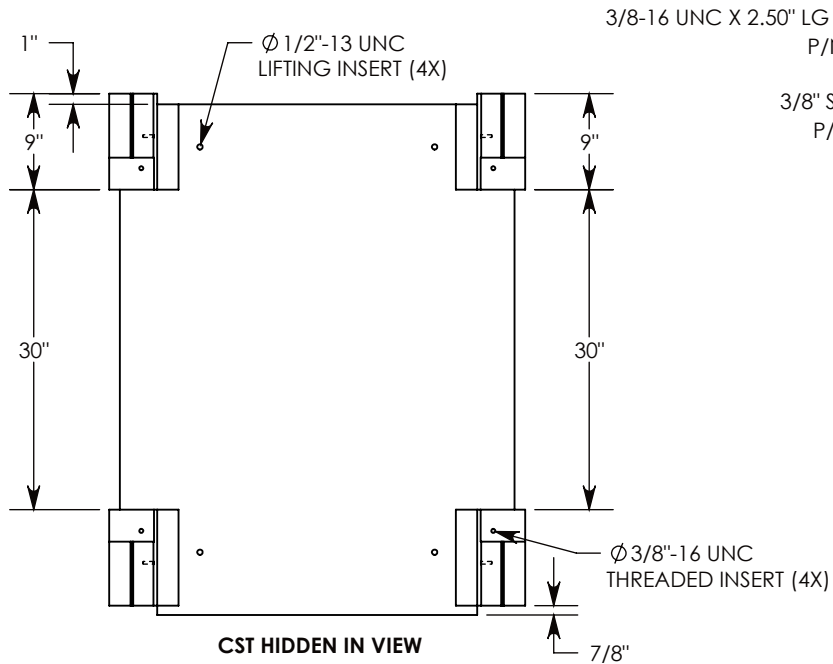

AASHTO H-20 RATED - 32,000 LB. SINGLE AXLE LOAD

DRAWN BY: ROSS LAGER	
DATE: 7/25/2019	REVISION LEVEL: B
WEIGHT: 883 LBS.	MATERIAL: NOTED

1010 NORTH STAR DRIVE
P.O. BOX 69
ZUMBROTA, MN 55992-0069

DESCRIPTION: HEAVY TRAFFIC UNIVERSAL CHANNEL		SHEET 1 OF 1
DIMENSIONS ARE IN INCHES TOLERANCES: FRACTIONAL: $\pm 1/8"$ ANGULAR: $\pm 2^\circ$	CONTACT INFORMATION: EMAIL: INFO@CONCASTINC.COM PHONE: (507) 732-4095 FAX: (507) 732-4094	
PART NUMBER: HTFU3016 (30X30)		