

Ø 1/2"-13 UNC INSERTS (4X)  
FOR LIFTING AND BOLT DOWN

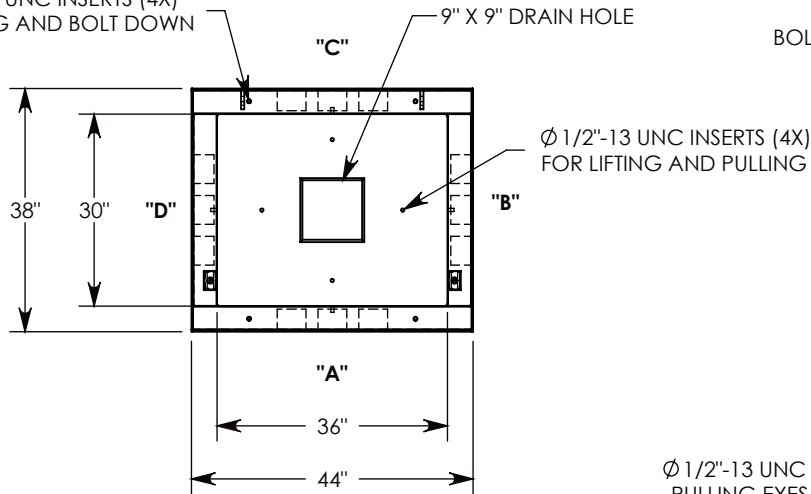

3/8-16 UNC X 1.5" LG HEX HD BOLT (2X)  
P/N: HHB.38-1.5

1/2-13 UNC X 1.5" LG HEX HD BOLT (4X)  
P/N: HHB.5-1.5

AL. FLOATING NUT; 2-3/4" X 1 X .5" THICK (2X)  
P/N: FLT-NUT-3

BOLT-DOWN STEEL GALV. FRAME & SPA COVER  
~298 LBS  
P/N: 38-44-SPA

CONCRETE PULL BOX  
~2729 LBS  
P/N: PB9-38-44-53

CON-DUCT TERMINATIONS ARE CAST  
INTO BOX SIDEWALLS. 9 PER SIDE (4X)  
THEY FIT UP TO 4" PVC PIPE. TO ACCESS  
THE HOLES, BREAK THE PLASTIC SEAL

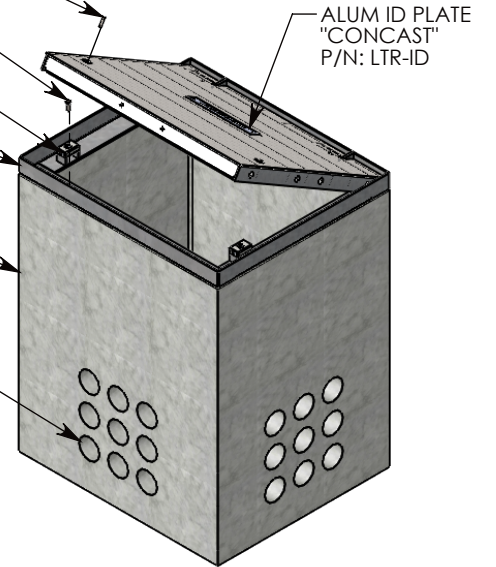

Ø 1/2"-13 UNC INSERT (4X) FOR  
PULLING EYES. LOCATED ON  
BOX INTERIOR (1X PER SIDE)

COVER SHOWN IN THIS VIEW  
(CLOSED)

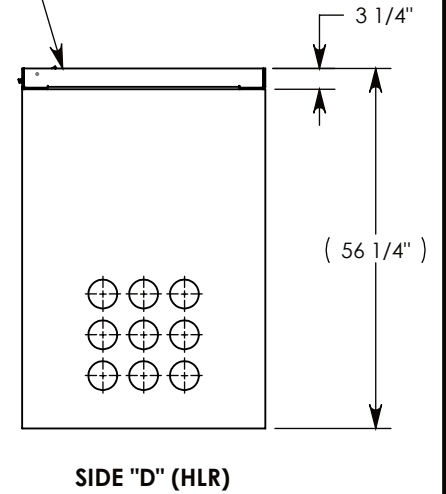
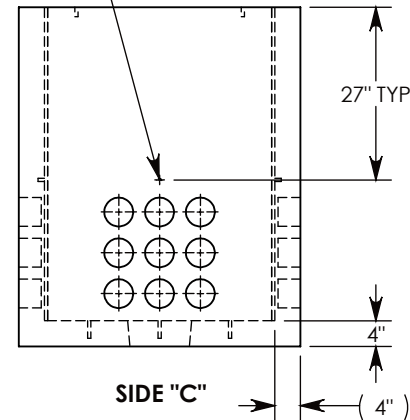
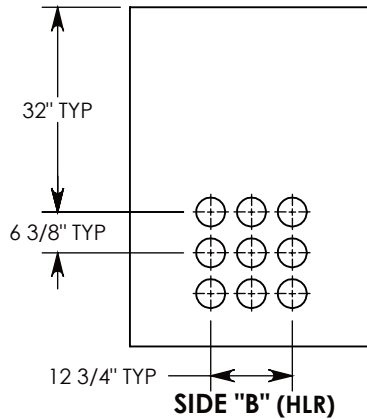
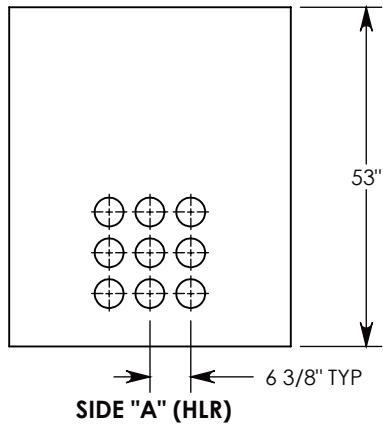

NOTE 1: FOR PVC SIZES SMALLER THAN 4", USE CONCAST RC41 (REDUCING COUPLER)

AASHTO H-20 RATED – 32,000 LB. SINGLE AXLE LOAD

DRAWN BY: **MALACHI MLINAR**

DATE: **11/7/2018**

REVISION LEVEL: **A**

WEIGHT:

**3028 LBS.**

MATERIAL:

**NOTED**



DESCRIPTION:

**CONCRETE PULL BOX W/RSG COVER**

DIMENSIONS ARE IN INCHES  
TOLERANCES:  
FRACTIONAL: ± 1/8"  
ANGULAR: ± 2°

CONTACT INFORMATION:  
EMAIL: [INFO@CONCASTINC.COM](mailto:INFO@CONCASTINC.COM)  
PHONE: (507) 732-4095  
FAX: (507) 732-4094

SHEET 1 OF 1

PART NUMBER:

**PB9-38-44-53-SPA**