

Ø 1/2"-13 UNC INSERT (4X) FOR
PULLING EYES. LOCATED ON
BOX INTERIOR (1X PER SIDE)

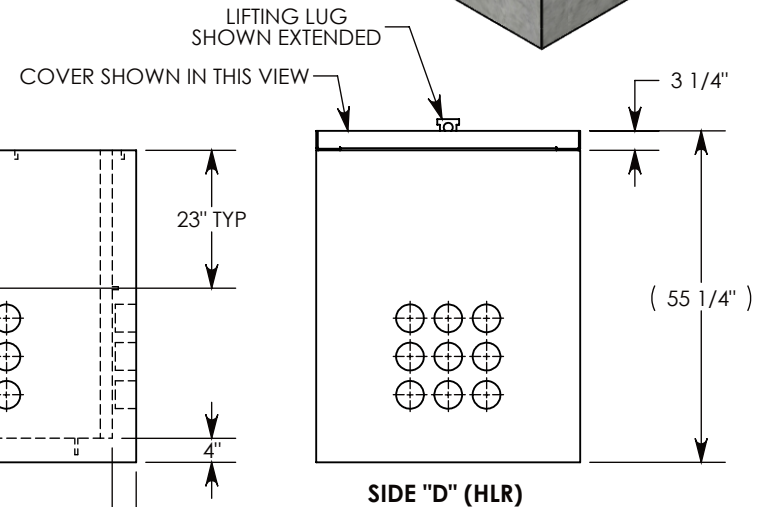
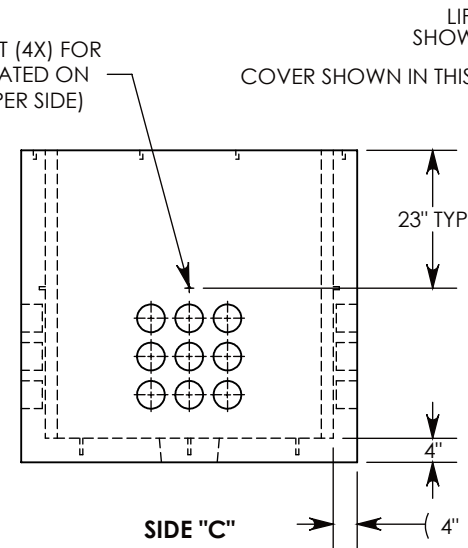
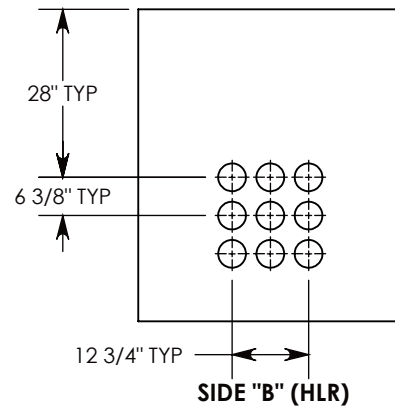
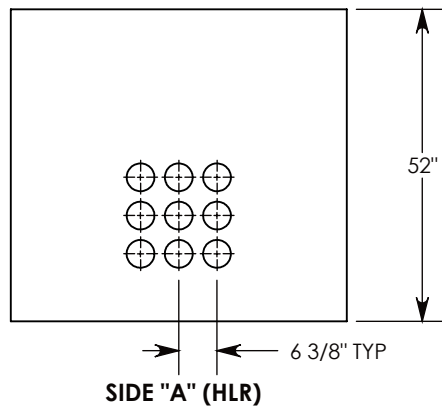

NOTE 1: FOR PVC SIZES SMALLER THAN 4", USE CONCAST RC41 (REDUCING COUPLER)

NOTE 2: FOR ADDED SECURITY, PENTA HEAD (P/N: PTA.38-1.5) OR SURELOCK BOLTS (P/N: SL.38-1.25) CAN BE ADDED

AASHTO H-20 RATED - 32,000 LB. SINGLE AXLE LOAD

DRAWN BY: ROBIN FLINT

DATE: 3/14/2019

REVISION LEVEL: B

WEIGHT:

3956 LBS. W/COVER

MATERIAL:

NOTED



DESCRIPTION:

PULL BOX W/ GALV. STEEL COVER

DIMENSIONS ARE IN INCHES
 TOLERANCES:
 FRACTIONAL: ± 1/8"
 ANGULAR: ± 2°

CONTACT INFORMATION:
 EMAIL: INFO@CONCASTINC.COM
 PHONE: (507) 732-4095
 FAX: (507) 732-4094

SHEET 1 OF 1

PART NUMBER:

PB9-44-56-52-RSG