

Ø 1/2"-13 UNC INSERT (4X) FOR PULLING EYES. LOCATED ON BOX INTERIOR (1X PER SIDE)

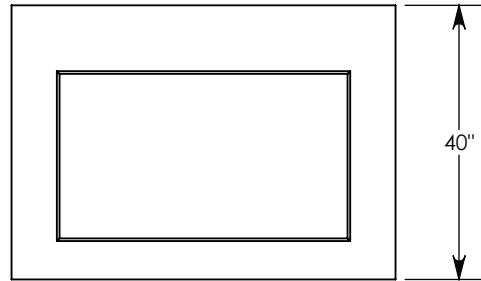

SIDE "A" (HLR)

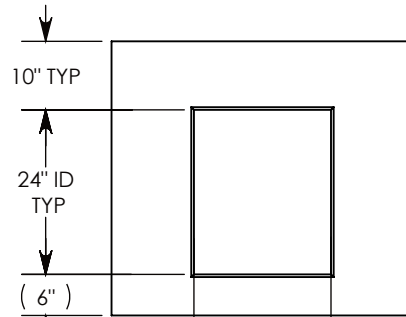

SIDE "B" (HLR)

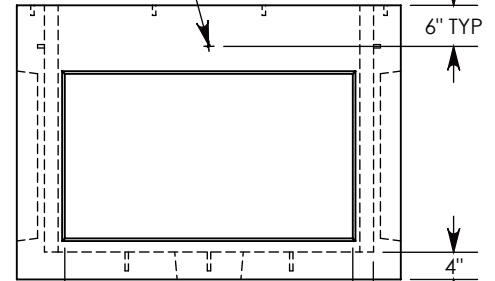

SIDE "C"

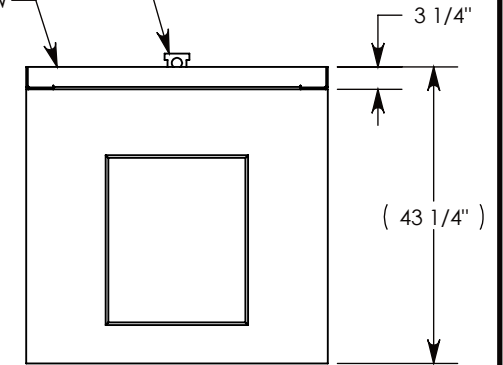

SIDE "D" (HLR)

NOTE 1: FOR ADDED SECURITY, PENTA HEAD (P/N: PTA.38-1.5) OR SURELOCK BOLTS (P/N: SL.38-1.25) CAN BE ADDED

AASHTO H-20 RATED - 32,000 LB. SINGLE AXLE LOAD

DRAWN BY: ROBIN FLINT		 1010 NORTH STAR DRIVE P.O. BOX 69 ZUMBROTA, MN 55992-0069	DESCRIPTION:	
DATE: 3/14/2019	REVISION LEVEL: B		PULL BOX W/ GALV. STEEL COVER	
WEIGHT: 2646 LBS. W/COVER	MATERIAL: NOTED		DIMENSIONS ARE IN INCHES TOLERANCES: FRACTIONAL: ± 1/8" ANGULAR: ± 2°	CONTACT INFORMATION: EMAIL: INFO@CONCASTINC.COM PHONE: (507) 732-4095 FAX: (507) 732-4094
		PART NUMBER:		
		PBK01-44-56-40-RSG		