

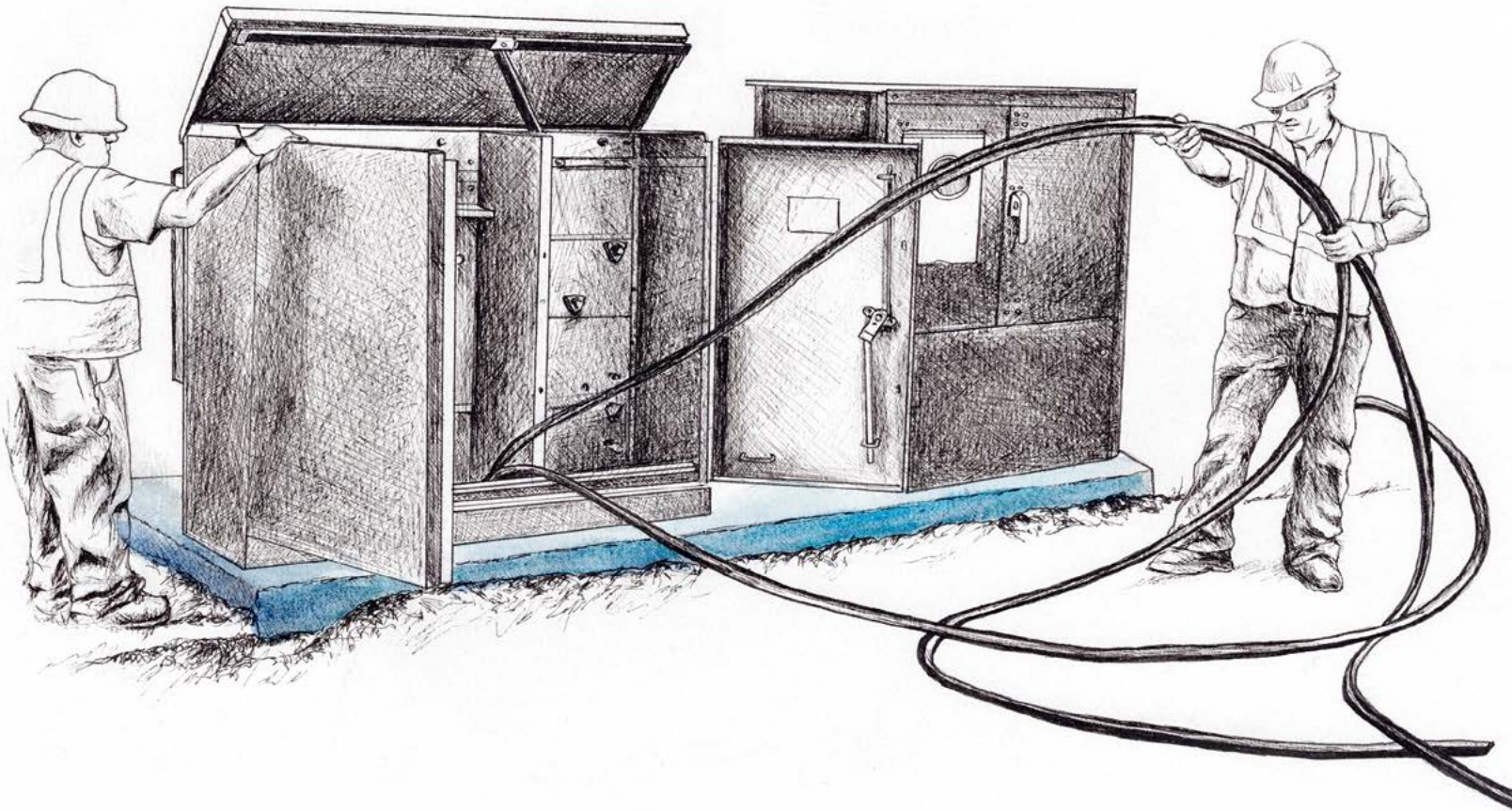

CONCAST

Fibercrete®

PRECISELY ENGINEERED HIGH STRENGTH CONCRETE



FLAT PADS



IDEAL USES FOR CONCAST FLAT PADS



GENERATOR BASE



**SINGLE PHASE
TRANSFORMER BASE**



**THREE PHASE
TRANSFORMER BASE**



**SPLIT PADS FOR
REPLACEMENT**



**SWITCHGEAR
BASE**



**TELECOMMUNICATION
CABINET BASE**

- Concast flat pads provide a stable and attractive base for any utility pad mount apparatus.
- Fibercrete® flat pads have a very high strength to weight ratio; yielding a relatively light-weight though extremely tough unit that saves on handling and shipping costs.
- Low in-place cost, plus the proven durability of Concrete & Fibercrete® add up to a truly economical flat pad installation option.

Guide Specifications

Flat Pads shall be constructed with Concast Fibercrete® or approved equal. It shall be composed of cement mortar; and reinforced by alkali resistant fiber and deformed high tensile wire or rebar.

Complete recommended specifications can be found in this catalog and online at www.concastinc.com/product_specs/index.php

Detail Drawings Provided

Concast will provide detail drawings for engineering approval, and to assist the construction crew with installation. Drawings of standard flat pads can be accessed online.

You can access the installation guidelines online at www.concastinc.com; keyword "guidelines"



Flat Pad Overview

REDUCE INSTALLATION COSTS WITH CONCAST'S FIBERCRETE® FLAT PADS

IN-PLACE COST IS LESS than site-cast concrete, conventional precast concrete, plastic mortars, or fiberglass plastics.



Benefits:

- **HANDLING IS EASY.** A crew of 2 or 3 can install a small flat pad without using hoisting equipment. The lightweight pad construction saves on shipping costs.
- **HIGH STRENGTH MATERIAL.** Fibercrete® fabrication results in a thin-walled product with high strength; providing safe, reliable support for electrical apparatus. Bottom rib design supports normal equipment loads without sinking.
- **LONG LIFE.** Concrete construction means long life, plus fire and corrosion resistance. Inert mineral composition resists temperature extremes, rain, and UV degradation.
- **IMPACT RESISTANT.** Fibercrete® has about three times the impact resistance of ordinary concrete. In addition, the bases are designed with smooth rounded corners, which result in superior resistance to damage or abrasion from mowers, snow plows, and vandals.
- **RODENT PROOF.** Tough Fibercrete® and concrete is resistant to gnawing animals.
- **FLAT & RIGID.** Fibercrete® and concrete pads stay rigid and flat. They will not warp, providing a safe and secure installation. The concrete material's rigidity naturally resists the "racking" and door damming that occurs if equipment enclosures do not rest on a level surface.
- **NATURAL APPEARANCE.** Smooth, stone-like surfaces blend with natural environment.



FLAT PADS



Features:

- **VARIABLE OPENING.** Fibercrete® and concrete flat pads can be produced with window openings as needed.

Fibercrete® Flat Pads

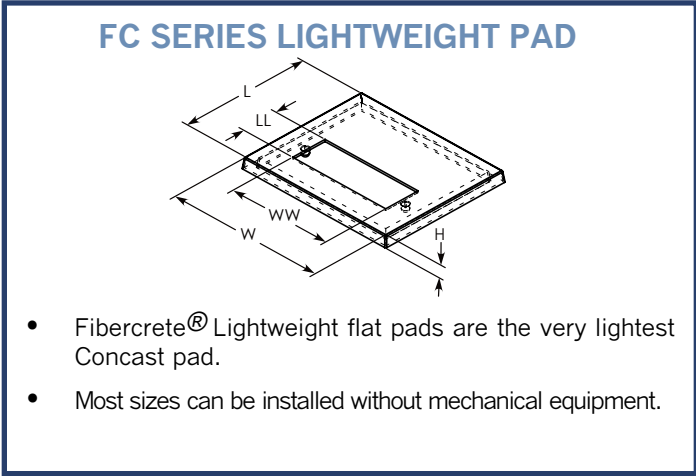

FIBERCRETE® LIGHTWEIGHT FLAT PADS	PAD LENGTH "L"	PAD WIDTH "W"	PAD HEIGHT "H"	PAD OPENING "LL x WW"	OFFSET DIST. "C"
FC-26-52-4-1126 (6)	26"	52"	4"	11 x 25.75	6"
FC-30-30-3-1016 (6)	30"	30"	3"	10 x 16	6"
FC-38-42-3.25-2012 (8)	38"	42"	3.25"	20 x 12	7.75"
FC-40-40-3.5-1225 (6)	40"	40"	3.5"	12 x 25	6"
FC-42-42-4-1326 (5)	42"	42"	4"	13 x 25.75	5"
FC-42-45-4-2512 (6)	42"	45"	4"	25 x 12	6"
FC-42-48-4-2612 (4)	42"	48"	4"	26 x 12	4"
FC-42-48-4-2626 (4)	42"	48"	4"	26 x 26	4"
FC-44-57-4-2915 (6)	44"	57"	4"	29 x 15	6"
FC-46-46-4-1228 (7)	46"	46"	4"	12 x 28	7"
FC-48-48-4-1227 (8)	48"	48"	4"	12 x 27	8"
FC-48-54-4-1225 (6)	48"	54"	4"	12 x 25	6"

- The listed standard Concast, Inc. flat pads are designed to support transformers, switchgear, and other electrical equipment.
- Standard cable openings are listed. If other openings sizes are required, please specify when ordering. For additional available sizes, please contact your local representative.
- PDF drawings can be [viewed online](#).



FPS Solid Flat Pads

FPS SERIES SOLID CONCRETE PAD

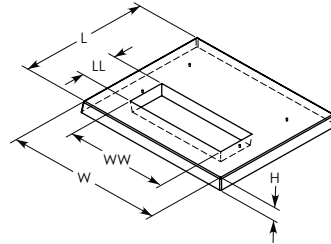

- Solid concrete pads are most economical of the Concast flat pad line.
- Will support heavier electrical equipment, and are ideal where pad weight is not an issue.
- Perfect for wet soil condition installations.
- Solid flat pads have an FPS prefix.

SOLID CONCRETE FLAT PADS	PAD LENGTH "L"	PAD WIDTH "W"	PAD HEIGHT "H"	PAD OPENING "LL x WW"	OFFSET DIST. "C"
FPS-26-52-4-1126 (6)	26"	52"	4"	11 x 25.75	6"
FPS-30-30-3-1016 (6)	30"	30"	3"	10 x 16	6"
FPSS-36-36-4-1218(6)	36"	36"	4"	12 X 18	6"
FPSS-36-72-4-1248(6)	36"	72"	4"	12 X 48	6"
FPS-38-42-3.25-2012 (8)	38"	42"	3.25"	20 x 12	7.75"
FPS-40-40-3.5-1225 (6)	40"	40"	3.5"	12 x 25	6"
FPS-42-42-4-1326 (5)	42"	42"	4"	13 x 25.75	5"
FPS-42-45-4-2512 (6)	42"	45"	4"	25 x 12	6"
FPS-42-48-4-2612 (4)	42"	48"	4"	26 x 12	4"
FPS-42-48-4-2626 (4)	42"	48"	4"	26 x 26	4"
FPS-44-57-4-2915 (6)	44"	57"	4"	29 x 15	6"
FPS-46-46-4-1228 (7)	46"	46"	4"	12 x 28	7"
FPS-48-48-4-1227 (8)	48"	48"	4"	12 x 27	8"
FPS-48-54-4-1225 (6)	48"	54"	4"	12 x 25	6"
FPS-58-70-5-1646 (12)	58"	70"	5"	16 x 46	12"
FPS-60-68-5-3215(6)	68"	60"	5"	15 x 32	6"
FPS-60-84-5-1548 (6)	60"	84"	5"	15 x 48	6"
FPS-65-72-4-1649 (6)	65"	72"	4"	16 x 49	6"
FPS-72-84-5-1649 (12)	72"	84"	5"	16 x 49	12"
FPS-72-84-5-2052 (10)	72"	84"	5"	20 x 52	10"
FPS-100-100-8-2068 (10)	99.5"	99.5"	8"	20 x 68	10"



LIGHTWEIGHT CUSTOM FLAT PAD

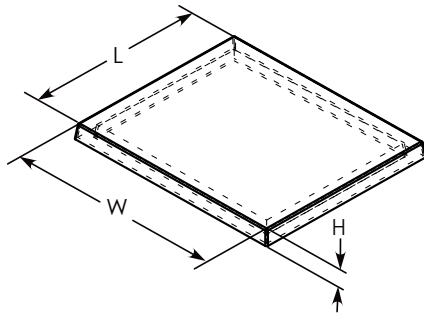

- Fibercrete® Lightweight flat pads are the very lightest pad we manufacture.
- Most sizes can be installed without the aid of mechanical maneuvering equipment.
- Toggle nuts are often used with these pads for onsite/field equipment installations.

Concast has an online form to help with the selection process at www.concastinc.com/flat_pads/help.php

SOLID CONCRETE CUSTOM FLAT PAD

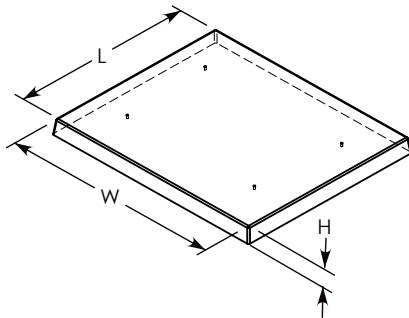

- Solid concrete pads are the most economical of the Concast flat pad line.
- Will support heavier electrical equipment, and are ideal where pad weight is not an issue.
- Perfect for wet soil condition installations.
- Solid flat pads have an FPS prefix.
- Wedge anchors are available from Concast for onsite/field equipment installations.

FIBERCRETE® LIGHTWEIGHT CUSTOM FLAT PADS	SOLID CONCRETE CUSTOM FLAT PADS	PAD LENGTH "L"	PAD WIDTH "W"	PAD HEIGHT "H"
FC-12-12-4	FPS-12-12-4	12"	12"	4"
FC-12-24-4	FPS-12-24-4	12"	24"	4"
FC-12-36-4	FPS-12-36-4	12"	36"	4"
FC-24-24-4	FPS-24-24-4	24"	24"	4"
FC-24-36-4	FPS-24-36-4	24"	36"	4"
FC-24-48-4	FPS-24-48-4	24"	48"	4"
FC-36-36-4	FPS-36-36-4	36"	36"	4"
FC-36-48-4	FPS-36-48-4	36"	48"	4"
FC-36-60-4	FPS-36-60-4	36"	60"	4"
FC-36-72-4	FPS-36-72-4	36"	72"	4"
FC-48-48-4	FPS-48-48-4	48"	48"	4"
FC-48-60-4	FPS-48-60-4	48"	60"	4"
FC-48-72-4	FPS-48-72-4	48"	72"	4"
FC-48-84-4	FPS-48-84-4	48"	84"	4"
FC-48-96-4	FPS-48-96-4	48"	96"	4"
N/A	FPS-60-60-5	60"	60"	5"
N/A	FPS-60-72-5	60"	72"	5"
N/A	FPS-60-84-5	60"	84"	5"
N/A	FPS-60-96-5	60"	96"	5"
N/A	FPS-72-72-5	72"	72"	5"
N/A	FPS-72-84-5	72"	84"	5"
N/A	FPS-72-96-5	72"	96"	5"
N/A	FPS-84-84-5	84"	84"	5"
N/A	FPS-84-96-5	84"	96"	5"
N/A	FPS-100-100-5	99.5"	99.5"	5"

FLAT PAD CUSTOMIZATION OPTIONS:

- Hold-down clamps
- Threaded inserts
- Unistrut Channel
- Toggle Nuts
- Custom Holes/Openings
- Wedge Anchors

Custom Pad Mark-up Sheet



PRINT AND MARK-UP THIS DRAWING WHEN ORDERING CUSTOM FLAT PADS

FIBERCRETE®

FIBER & WIRE REINFORCED CONCRETE

PRINT THIS PAGE AND FILL IN THE DIMENSIONS OF THE CUSTOM SIZE FLAT PAD NEEDED

W-___ L-___ WW-___ H-___ LL-___ X-___

PART NUMBERING CONVENTION: FP-W-L-H (WWLL)X
WIDTH & LENGTH ARE INTERCHANGEABLE; THE SMALLEST DIMENSION IS ALWAYS LISTED FIRST.

PLEASE NOTE THAT TYPICALLY THE OPENING OR THROAT IS CENTERED ON THE "W" DIMENSION. IF AN OFFSET OPENING IS REQUIRED, SPECIFY BY ADDING A DIMENSION OFF OF THE EDGE. IF MULTIPLE OPENINGS ARE NEEDED, DRAW IN THEIR LOCATIONS ON THE TOP VIEW OF THE PRINT.

SKETCH IN ANY CAST-IN HARDWARE REQUIRED

___ - CHECK IF SOLID-BOTTOM PAD IS REQUIRED

___ - QTY REQUIRED

DRAWN BY: ROBIN FLINT

DATE: 12/21/2011

REVISION LEVEL: 0

WEIGHT: -- LBS.

MATERIAL: FIBERCRETE FC

1010 NORTH STAR DRIVE
P.O. BOX 69
ZUMBROTA, MN 55992-0069

DESCRIPTION: **GENERIC FIBERCRETE FLAT PAD**

DIMENSIONS ARE IN INCHES	CONTACT INFORMATION:
TOLERANCES: FRACTIONAL: ± 1/8" ANGULAR: ± 2°	EMAIL: INFO@CONCASTINC.COM
PART NUMBER: FP-___-___-___	PHONE: (507) 732-4095
	FAX: (507) 732-4094

SHEET 1 OF 1

FLAT PADS



Transformer Flat Pads

SINGLE PHASE TRANSFORMER FLAT PADS

SINGLE PHASE TRANSFORMER SOLID CONCRETE FLAT PADS	PAD LENGTH "L"	PAD WIDTH "W"	PAD HEIGHT "H"	PAD OPENING "LL x WW"	OFFSET DIST. "C"	LIGHTWEIGHT PAD OPTION (FC)
FPS-30-30-3-1016 (6)	30"	30"	3"	10 x 16	6"	✓
FPS-38-42-3.25-2012 (8)	38"	42"	3.25"	20 x 12	8"	✓
FPS-40-40-3.5-1225 (6)	40"	40"	3.5"	12 x 25	6"	✓
FPS-42-42-4-1224(6)	42"	42"	4"	12 x 24	6"	✓
FPS-42-45-4-2512 (6)	42"	45"	4"	25 x 12	6"	✓
FPS-42-48-4-2612 (4)	42"	48"	4"	26 x 12	4"	✓
FPS-42-48-4-2626 (4)	42"	48"	4"	26 x 26	4"	✓
FPS-44-57-4-2915 (6)	44"	57"	4"	29 x 15	6"	✓
FPS-46-46-4-1228 (7)	46"	46"	4"	12 x 28	7"	✓
FPS-48-48-4-1227 (8)	48"	48"	4"	12 x 27	8"	✓
FPS-48-54-4-1225 (6)	48"	54"	4"	12 x 25	6"	✓

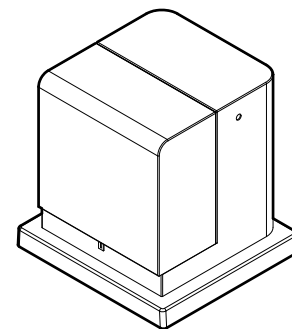

- You can access PDF drawings of all of these transformer flat pads at [online](#).
- Concast has an [online form](#) to help with the selection process.

3 PHASE TRANSFORMER FLAT PADS

THREE PHASE TRANSFORMER SOLID CONCRETE FLAT PADS	PAD LENGTH "L"	PAD WIDTH "W"	PAD HEIGHT "H"	PAD OPENING "LL x WW"	OFFSET DIST. "C"	LIGHTWEIGHT PAD OPTION (FC)
FPS-58-70-5-1646 (12)	58"	70"	5"	16 x 46	12"	✓
FPS-60-84-5-1548 (6)	60"	84"	5"	15 x 48	6"	✓
FPS-65-72-4-1649 (6)	65"	72"	4"	16 x 49	6"	✓
FPS-72-84-5-1649 (12)	72"	84"	5"	16 x 49	12"	✓
FPS-72-84-5-2052 (10)	72"	84"	5"	20 x 52	10"	✓

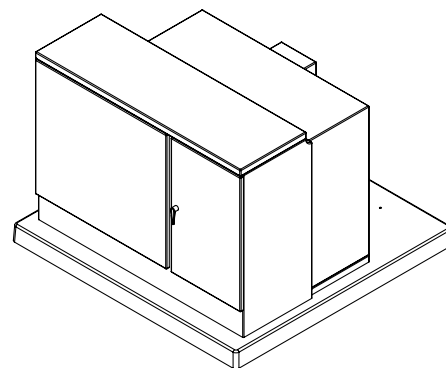



Split Pads & Applications

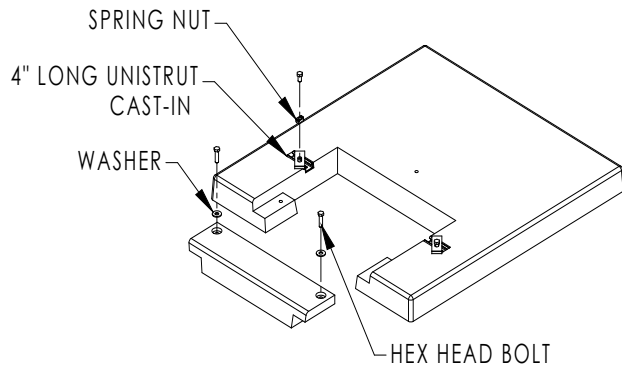

SPLIT FLAT PADS

Fibercrete® split flat pads are ideal for instances where an existing pad is damaged and needs to be replaced. Concast's split pad design features two pad pieces with connecting hardware as shown.

Replacement Procedure:

- Lift equipment from existing pad. It is generally not necessary to disconnect the cables.
- Cut out the existing pad.
- Slide the new Fibercrete® split pad into place, and bolt the two pieces together using the hardware provided.
- Re-attach the equipment to the new flat pad.

STD. SPLIT PAD WAFFLE BOTTOM	PAD LENGTH "L"	PAD WIDTH "W"	PAD HEIGHT "H"	PAD OPENING "LL x WW"	OFFSET DIST. "C"
FP-30-30-3-1016(6)-SPL	30"	30"	3"	10 x 16	6
FP-40-40-3.5-1225(6)-SPL	40"	40"	3.5"	12 x 25	6
FP-42-42-4-1326(5)-SPL	42"	42"	4"	13 x 25.75	5
FP-42-45-4-2512(6)-SPL	42"	45"	4"	12 x 20	6
FP-42-48-4-2612(6)-SPL	42"	48"	4"	12 x 26	6

FLAT PADS

GENERATOR LIGHTWEIGHT FLAT PADS	GENERATOR SOLID FLAT PADS	LENGTH "L"	WIDTH "W"	HEIGHT "H"
FC-24-36-4	FPS-24-36-4	24"	36"	4"
FC-24-48-4	FPS-24-48-4	24"	48"	4"
FC-26-52-4	FPS-26-52-4	26"	52"	4"
FC-36-36-4	FPS-36-36-4	36"	36"	4"
FC-36-48-4	FPS-36-48-4	36"	48"	4"
FC-36-60-4	FPS-36-60-4	36"	60"	4"
FC-36-72-4	FPS-36-72-4	36"	72"	4"
FC-48-48-4	FPS-48-48-4	48"	48"	4"
FC-48-60-4	FPS-48-60-4	48"	60"	4"
FC-48-72-4	FPS-48-72-4	48"	72"	4"
FC-48-84-4	FPS-48-84-4	48"	84"	4"
FC-48-96-4	FPS-48-96-4	48"	96"	4"

INDUSTRIAL GENERATOR FLAT PADS

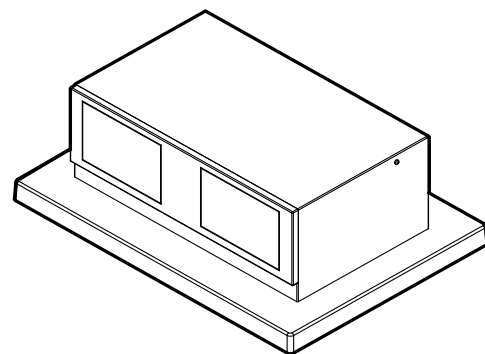

Toggle nuts are available. These can be used so that mounting holes can be precisely located, and then field-drilled for easy installation of the cabinet via its bolt pattern. Other available mounting options include clamps, cast-in threaded inserts and unistrut.

Fibercrete® Flat Pads



TELECOMMUNICATION INDUSTRY FLAT PADS

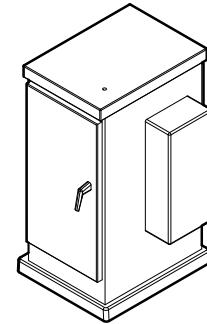

SYSTEM VI FLAT PADS

Concast can build specialty modular flat pad systems to support the S & C Electric Company System VI Metal Enclosed Switchgear. Send the footprint details of the cabinets in your application, and the engineering team at Concast will design a custom pad configuration. We offer many customization options including clamps, threaded inserts, unistrut, knockouts, and holes. If other hardware is needed, please specify when ordering.

This system allows a continuous raceway below each S&C unit in the System VI line-up. To install the modular flat pad system, backfill against the exterior of the installed trench channels, and place the flat pads over the channels. The cable openings in the pad must be positioned to allow access into channels below.

TELECOM. LIGHTWEIGHT FLAT PADS	LENGTH "L"	WIDTH "W"	HEIGHT "H"
FC-12-12-4	12"	12"	4"
FC-12-24-4	12"	24"	4"
FC-12-36-4	12"	36"	4"
FC-24-24-4	24"	24"	4"
FC-24-36-4	24"	36"	4"
FC-24-48-4	24"	48"	4"
FC-26-52-4	26"	52"	4"
FC-36-36-4	36"	36"	4"
FC-36-36-4-CW	36"	36"	4"
FC-36-48-4	36"	48"	4"
FC-36-60-4	36"	60"	4"
FC-36-72-4	36"	72"	4"
FC-36-72-4-CW	36"	72"	4"



SYSTEM VI

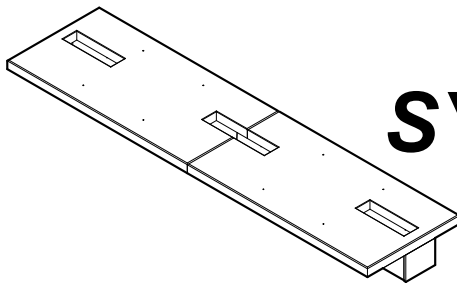

SUPPORT PADS



4-WAY LIFT CHAIN

- Concast Part Number: 9003
- Can be used in conjunction with the Swivel Hoist Rings for lifting heavy box pads.
- The 9100 pound maximum rated load is contingent on maintaining a horizontal lift angle that is less than 60 degrees



Flat Pad Accessories

WEDGE ANCHOR	THREAD DIAMETER	ANCHOR LENGTH	FINISH
WA.38-3.75	3/8"	3-3/4"	ZINC
WA.5-3.75	1/2"	3-3/4"	ZINC
WA.38-3.75-SS	3/8"	3-3/4"	STAINLESS STEEL
WA.5-3.75-SS	1/2"	3-3/4"	STAINLESS STEEL

WEDGE ANCHORS

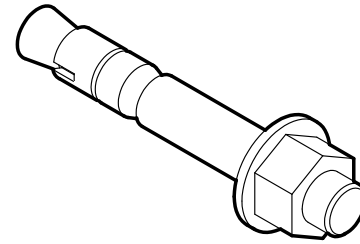

Concast wedge anchors can be used in the FPS style flat pads. They feature a single piece expansion clip, a threaded stud bolt body, integral cone expander, nut and washer. Anchor bodies are made of zinc plated carbon steel, or stainless steel. Stainless steel anchors will have a "-SS" suffix in the part number.

FLAT PADS

MOUNTING HARDWARE

Mounting hardware can be supplied with any flat pad upon request. All mounting clamp hardware is standard yellow zinc plated but other finishes are also available.

Hold Down Clamp:

- Concast Part Number: HDC-1
- Includes 1/2" dia. bolt.
- Used with a drilled hole or a threaded insert.

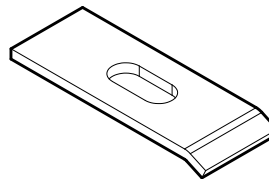

Threaded Insert

- Cast into top of flat pad.
- Available in 1/4" to 1" diameter.
- Used for lifting or equipment mounting.

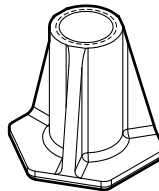

Threaded Studs

- Cast into top of flat pad.
- Used for mounting equipment

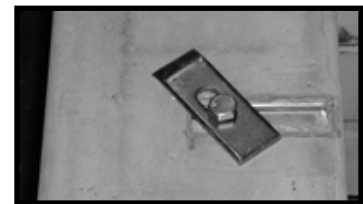

Unistrut Channel w/Spring Nut

- Cast into top of flat pad.
- Provides adjustable mounting option.

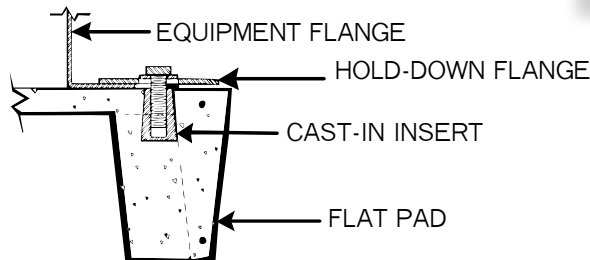



Flat Pad Accessories

SEALANT



Vulkem polyurethane sealant is colored concrete gray and can be ordered under Concast P/N: 8004. It is delivered in tubes and is designed for use on poured and precast concrete surfaces. Vulkem 116 has demonstrated superior primerless adhesion to porous substrates for over 30 years and is the sealant of choice for commercial industrial expansion joints.

PATCH KITS

PK-1 Patch Kit:

- Used for cosmetic repairs.
- Kit is complete with everything you need for small concrete repairs, including patching compound, bucket, and a trowel.



PK-2 Patch Kit:

- Ideal for patching holes in non-structural concrete sections.
- Kit consists of a large Fibercrete® patch sheet (1/2" thick by 12" sq.) which is cut to size, and then a construction adhesive or concrete screws are used to attach the patch over the hole.



PK-36, PK-69, & PK-912 PatchKwik Kits

- Easy to apply, self-adhesive fiberglass patch that is UV light activated. Available in 3 sizes.
- Spray paint can be ordered from Concast in gray or green. Part numbers are PK-Gray & PK-Green respectively.
- More detail [online](#).



[PatchKwik Installation Video](#)
[Patch Kit Link](#)

GUIDE POSTS & SAFETY CHAIN

Guide posts and chain provide protection for your pre-cast flat pads by blocking off vehicular traffic or defining a road way. A hard, yellow plastic exterior ensures that the color will withstand years of environmental exposure like UV rays and heat. The posts are available either hollow, or concrete filled with steel rebar reinforcement. A 3/8-16 UNC threaded insert is located at the top of each post for securing optional safety chain. See [more online](#).



Post, Rope & Chain Part Numbers	Connection Hardware Part Numbers
8005Y-4F	9001G
8005Y-4H	9001SS
8005Y-7F	9001Z
8005Y-7H	9001G-J
8007	9001SS-J
8007Y-3	9001ACC
8007SG	HHB.38-1.5
ROPE-5-BK	WSR.38-1
ROPE-5-YW	8007SG-CL
	ROPE-CLAMP-625
	SHSS
	SHPY-3

FLAT PADS



Flat Pad Accessories

TOGGLE NUTS



Threaded toggle nuts are yet another way to mount your electrical equipment onto Concast's precast box pads. These nuts are installed onsite; allowing greater mounting flexibility and accuracy. They utilize a simple stabilizing technique similar to drywall anchors.

An installation video is [available online](#)

TOGGLE NUT	NUT THREAD DIAMETER
TN.25	1/4-20 UNC
TN.375	3/8-16 UNC
TN.5	1/2-13 UNC



FLAT PADS

INSERT PLUGS

Concast casts threaded inserts into many of their heavier box pads that require mechanical assistance to maneuver them. To keep these inserts from filling with debris and water, Concast offers a line of insert plugs. Available in both plastic and in stainless steel.



INSERT PLUG	PLUG FIT DIAMETER	PLUG DESCRIPTION
IPP.375	3/8"	Plastic Plug
IPP.5	1/2"	Plastic Plug
IPB.375	3/8-16 UNC	SS Hex Head Bolt
IPB.5	1/2-13 UNC	SS Hex Head Bolt
IPS.38	3/8"	SS Socket Head Set Screw
IPS.5	1/2"	SS Socket Head Set Screw





GENERAL SPECIFICATIONS FOR FLAT PADS

1. TECHNICAL SCOPE

- 1-A.** These specifications cover precast Fibercrete® (G.F.R.C.) flat pads manufactured by Concast Incorporated in Zumbrota, Minnesota. The manufacturer must have experience in design and fabrication of these products and also the facilities for fabricating them with the quality specified herein and without delay to the agreed upon schedule.
- 1-B.** The flat pads shall be designed and constructed to provide a serviceable life and warranty of 35 years when installed outdoors in full sunlight and without any protection from the weather at any location in the continental United States or Canada.
- 1-C.** The Supplier shall design, construct, perform dimensional and quality control tests, and prepare the pads for truck shipment. Shipping and delivery responsibilities will be defined in the project specific purchase documents. The Supplier shall provide all necessary documentation as stated in this specification.

2. DIMENSIONS AND DESIGN

- 2-A.** Drawings shall be made available for engineering approval, field installation, and field identification; in PDF, SolidWorks, or AutoCAD format. Standard PDF format component drawings shall also be available online.
- 2-B.** The tolerances of the dimensions of each flat pad shall not exceed $\pm 1/4"$. These tolerances apply to the components when ready for shipping, when set on a flat and level surface with no loads applied to it.
- 2-C.** The manufacturer's design dimensions must be approved by the Purchaser prior to fabrication.
- 2-D.** Flat pads shall be made available to fit design requirements and dimensions of the equipment being supported.
- 2-E.** Provisions, such as cast-in threaded inserts, must be offered for lifting any pad. Mounting holes must be adequately reinforced to avoid damaging the pad and to provide an ultimate strength of at least 5 times the pad weight when the part is lifted in accordance with the manufacturer's instructions.
- 2-F.** The flat pad shall have a rigid, flat, and stable top surface.
- 2-G.** The flat pad color shall be a natural concrete gray unless otherwise required and agreed upon.
- 2-H.** If required, the flat pad shall be manufactured with equipment bolt-down accommodations.
- 2-I.** The flat pad shall be designed and constructed so that it and any related hardware will not trap or hold water when required, and so that it will be able to withstand repeated freeze and thaw cycles.
- 2-J.** The Concast "Waffle Bottom Flat Pad" and the "Lightweight Flat Pad" is designed to permit loose earth to fill the bottom surface voids which level and stabilize the pad.
- 2-K.** The flat pad shall be designed to support specific equipment and applications
- 2-L.** The precast components are designed to conform to requirements stated in ASTM C857-07 "Practice for Minimum Structural Design Loading for Underground Precast Concrete Utility Structures, ASTM C858-07 "Specifications for Underground Precast Concrete Utility Structures".



Flat Pad Specifications

3. PERFORMANCE AND MATERIALS

- 3-A.** Cement shall conform to the requirements of ASTM C595 - Type II.
- 3-B.** Course and fine aggregates shall conform to ASTM C33 "Specification for Concrete Aggregates".
- 3-C.** Preparation of concrete shall conform to ASTM A94 "Specification for Ready-Mix Concrete" & ACI 304 "Guide for Mixing, Transporting and Placing Concrete".
- 3-D. LAY-UP GFRC (PART NUMBERS WITH FC PREFIX)**
 - 3-D.1** Composed of cement mortar reinforced by alkali resistant glass fiber, and deformed high tensile welded wire. It is fabricated via the Concast spray lay-up method which incorporates a minimum of 4 percent volume A.R. glass fibers.
 - 3-D.2** Flat pads shall conform to AIA Masterspec Section 03491 for Glass Fiber Reinforced Concrete and quality control procedures per PCI# MNL-130-91.
- 3-E. PREMIX GFRC (PART NUMBERS WITH FP OR FPSB PREFIX)**
 - 3-E.1** Composed of cement mortar reinforced by alkali resistant glass fiber, and a deformed prefabricated high tensile welded wire. It is fabricated via casting into steel forms.
 - 3-E.2** A.R. Glass is required to prevent glass deterioration if in contact with any poured cement or grout foundation.
 - 3-E.3** Shall obtain a minimum compressive strength of 6000 PSI at 28 days of age.
- 3-F. MICRO-CONCRETE (PART NUMBERS WITH FPS PREFIX)**
 - 3-F.1** Precast solid concrete flat pads shall be cast into steel forms.
 - 3-F.2** Concrete shall contain 6% entrained air (plus or minus 1%)
 - 3-F.3** Shall obtain a minimum compressive strength of 7500 PSI at 28 days of age.
- 3-G. REINFORCEMENT**
 - 3-G.1** Steel reinforcing bars shall conform to ASTM A615 "Specification for Deformed and Plain Billet Steel Bars for Concrete Reinforcement".
 - 3-G.2** Steel reinforcing wires shall conform to ASTM A496 "Specification for Steel Wire, Deformed for Concrete Reinforcement".
 - 3-G.3** Steel reinforcing weld wire cages shall conform to ASTM A497 "Specification for Steel Welded Wire Fabric, Deformed for Concrete Reinforcement".
- 3-H.** The flat pad must not be affected by asphalt, transformer oil, other common chemicals, weather, or other normal service conditions that it might be exposed to.



- 3-I.** The flat pad shall be designed and constructed so that it and any related hardware will not trap or hold water, and so that it will be able to withstand repeated freeze and thaw cycles.
- 3-J.** The flat pad must not warp, rust, be UV degradable, or sustain combustion.
- 3-K.** With equipment installed; the flat pad shall be capable of withstanding temperature variations of -40° Fahrenheit to 149° Fahrenheit without cracking, splitting, or otherwise deforming. Material shall have been tested and conform to ASTM C666/C666M-03.
- 3-L.** When required, site-specific, PE stamped, seismic calculations shall be provided.
- 3-M.** Concrete properties will vary depending upon the particular formulation of the concrete mix design. Customized properties can be achieved by using nonstandard ingredients, by changing or adding reinforcements, and by tailoring the overall mix design.

3-N. METAL COMPONENT PERFORMANCE

3-N.1 All galvanized steel covers, hardware, and embedments shall meet the following requirements:

- Steel Deck Plating - ASTM A786 | Steel Sheet - A1011 HSLAS Gr 50
- Steel Angles & Flats - ASTM A-36 | Galvanized Covers - ASTM 123
- Galvanized Hardware - ASTM 153

3-N.2 All stainless steel hardware and embedments shall meet the following requirements:

- Stainless Steel Angles & Flats Type 304 - ASTM A276
- Stainless Steel Sheet Type 304 - ASTM A-240

3-N.3 All aluminum covers, hardware, and embedments shall meet the following requirements:

- Aluminum Flats 6061-T6511 - ASTM B221 | Aluminum Sheet Smooth 5052-H32 - ASTM B209
- Aluminum Deck Plating 3003 - ASTM B209 or 6061 - ASTM B632
- Aluminum Angles 6061-T6 - ASTM B308 | Aluminum Channels 6061-T6 - ASTM B308

4. INSTALLATION REQUIREMENTS

- 4-A.** When the bottom of the excavation is soft, or where in the opinion of the soils engineer unsatisfactory foundation conditions exist, the contractor shall over excavate to a depth to ensure a proper foundation as directed by the soils engineer. The excavation can then be brought back up to the prescribed grade with a thoroughly compacted granular material.
- 4-B.** All flat pad excavations shall be backfilled to restore pre-existing conditions or to the final grade as specified by the owner.
- 4-C.** All backfill material shall be a granular material as required by the soils engineer. Flat pads shall be designed to have no limitations of backfill height.
- 4-D.** Installation guidelines shall be made available online.



Flat Pad Notes

FLAT PADS



CONCAST

P.O. Box 69
1010 North Star Drive
Zumbrota, MN 55992-0069

Revised 09/25/2025

