

**BASIC INSTALL:**

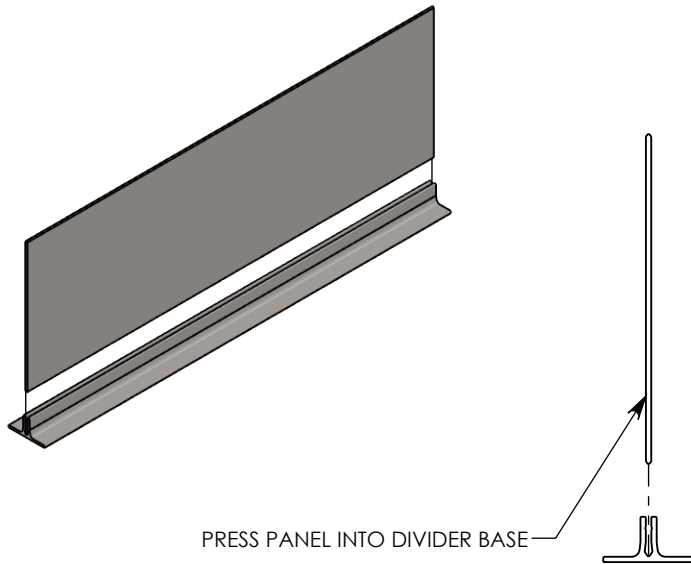

**OPTIONAL: ADHESIVE**

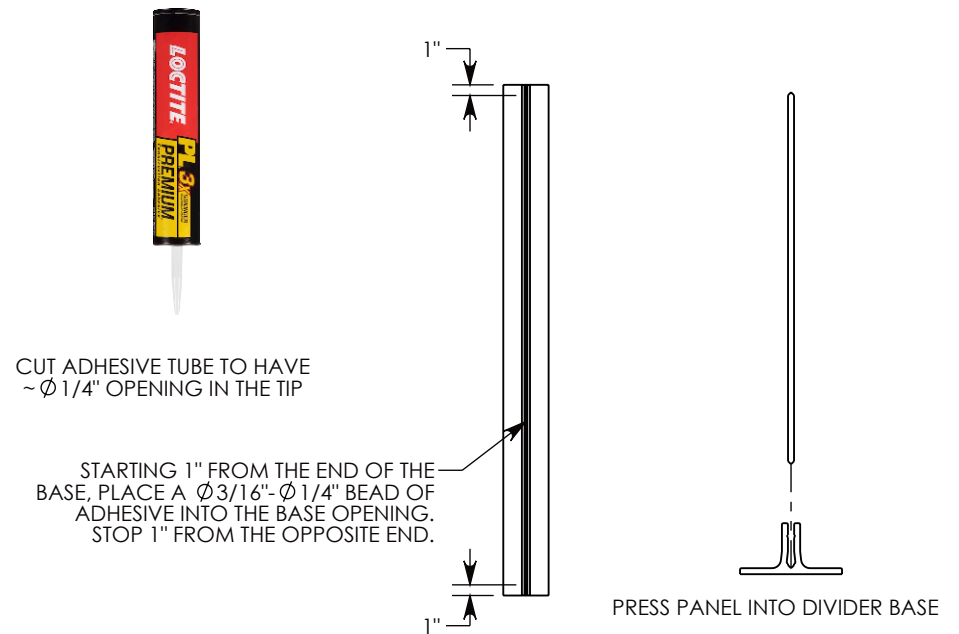

**OPTIONAL: BOLT DOWN**

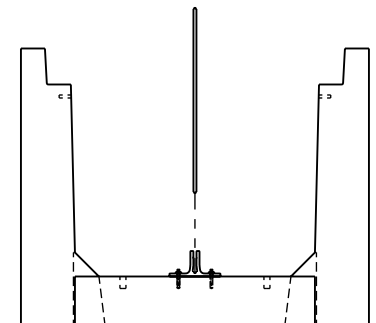
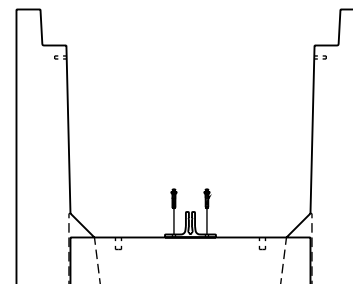
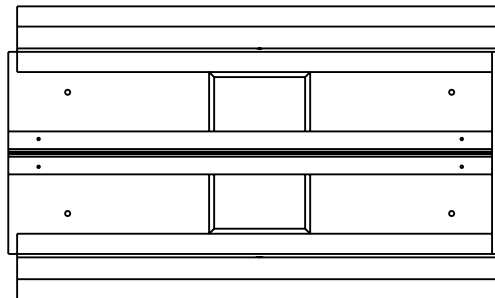
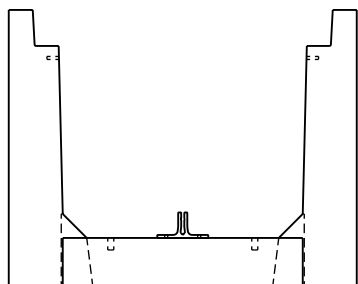

DRAWN BY: **JESSE GUTTING**

CREATED DATE: **7/8/2024** REVISION LEVEL: **0**

SAVED DATE: **7/11/2024** SAVED BY: **jgutting**

WEIGHT: ~ MATERIAL: **FRP**



DESCRIPTION:  
**INSTALL GUIDE**

DIMENSIONS ARE IN INCHES  
TOLERANCES:  
FRACTIONAL:  $\pm$  1/8"  
ANGULAR:  $\pm$  2°

CONTACT INFORMATION:  
EMAIL: [INFO@CONCASTINC.COM](mailto:INFO@CONCASTINC.COM)  
PHONE: (507) 732-4095  
FAX: (507) 732-4094

SHEET 1 OF 1

PART NUMBER:  
**FRP DIVIDER INSTALL**